

**DPO7000 Series and DSA/DPO70000 Series
Digital Phosphor Oscilloscopes
Quick Start User Manual**

Copyright © Tektronix. All rights reserved. Licensed software products are owned by Tektronix or its subsidiaries or suppliers, and are protected by national copyright laws and international treaty provisions.

Tektronix products are covered by U.S. and foreign patents, issued and pending. Information in this publication supersedes that in all previously published material. Specifications and price change privileges reserved.

TEKTRONIX and TEK are registered trademarks of Tektronix, Inc.

FastFrame, OpenChoice, iView, Pinpoint, RT-Eye, MyScope, TekLink, and MultiView Zoom are trademarks of Tektronix, Inc.

Contacting Tektronix

Tektronix, Inc.
14200 SW Karl Braun Drive
P.O. Box 500
Beaverton, OR 97077
USA

For product information, sales, service, and technical support:

- In North America, call 1-800-833-9200.
- Worldwide, visit www.tektronix.com to find contacts in your area.

Warranty 2

Tektronix warrants that this product will be free from defects in materials and workmanship for a period of one (1) year from the date of shipment. If any such product proves defective during this warranty period, Tektronix, at its option, either will repair the defective product without charge for parts and labor, or will provide a replacement in exchange for the defective product. Parts, modules and replacement products used by Tektronix for warranty work may be new or reconditioned to like new performance. All replaced parts, modules and products become the property of Tektronix.

In order to obtain service under this warranty, Customer must notify Tektronix of the defect before the expiration of the warranty period and make suitable arrangements for the performance of service. Customer shall be responsible for packaging and shipping the defective product to the service center designated by Tektronix, with shipping charges prepaid. Tektronix shall pay for the return of the product to Customer if the shipment is to a location within the country in which the Tektronix service center is located. Customer shall be responsible for paying all shipping charges, duties, taxes, and any other charges for products returned to any other locations.

This warranty shall not apply to any defect, failure or damage caused by improper use or improper or inadequate maintenance and care. Tektronix shall not be obligated to furnish service under this warranty a) to repair damage resulting from attempts by personnel other than Tektronix representatives to install, repair or service the product; b) to repair damage resulting from improper use or connection to incompatible equipment; c) to repair any damage or malfunction caused by the use of non-Tektronix supplies; or d) to service a product that has been modified or integrated with other products when the effect of such modification or integration increases the time or difficulty of servicing the product.

THIS WARRANTY IS GIVEN BY TEKTRONIX WITH RESPECT TO THE PRODUCT IN LIEU OF ANY OTHER WARRANTIES, EXPRESS OR IMPLIED. TEKTRONIX AND ITS VENDORS DISCLAIM ANY IMPLIED WARRANTIES OF MERCHANTABILITY OR FITNESS FOR A PARTICULAR PURPOSE. TEKTRONIX' RESPONSIBILITY TO REPAIR OR REPLACE DEFECTIVE PRODUCTS IS THE SOLE AND EXCLUSIVE REMEDY PROVIDED TO THE CUSTOMER FOR BREACH OF THIS WARRANTY. TEKTRONIX AND ITS VENDORS WILL NOT BE LIABLE FOR ANY INDIRECT, SPECIAL, INCIDENTAL, OR CONSEQUENTIAL DAMAGES IRRESPECTIVE OF WHETHER TEKTRONIX OR THE VENDOR HAS ADVANCE NOTICE OF THE POSSIBILITY OF SUCH DAMAGES.

Table of Contents

General Safety Summary	v
Environmental Considerations	vii
Preface	viii
Key Features	viii
Documentation	ix
Conventions Used in this Manual	x
Install Your Instrument	1
Standard Accessories	1
Operating Requirements	2
Powering On the Instrument	4
Powering Off the Instrument	5
Removing the Power	5
Connecting to a Network	6
Adding a Second Monitor	6
Creating Operating System Restore CD-ROMs	10
Getting Acquainted with Your Instrument	11
Front Panel	11
Side and Rear Panels	12
Interface and Display	13
Control Panel	16
Accessing Online Help	17
Accessing Menus and Control Windows	18
Inspect Your Instrument	19
Verify Internal Diagnostics Pass	19
Signal Path Compensation	20
Acquisition	23
Setting Up Signal Input	23
Using Default Setup	24
Using Autoset	25
Probe Compensation, Calibration, and Deskew	26
Acquisition Concepts	26
How the Acquisition Modes Work	28
Changing the Acquisition Mode	30
Starting and Stopping an Acquisition	31
Selecting the Horizontal Mode	31
Using FastAcq	34
Using DSP Enhanced Bandwidth	34
Using Roll Mode	37
Using FastFrame Mode	37
Using FastFrame Frame Finder	39
Pinpoint Triggers	42
Triggering Concepts	42

Choosing a Trigger Type	44
Pinpoint Trigger Selections	45
Checking Trigger Status	47
Using A (Main) and B (Delayed) Triggers	47
Sending E-mail on Trigger	51
Using Horizontal Delay.....	52
Display a Waveform	53
Setting the Display Style	53
Setting the Display Persistence	54
Setting the Display Format.....	55
Selecting the Waveform Interpolation	56
Adding Screen Text	57
Setting the Graticule Style	58
Setting the Trigger Level Marker	59
Displaying the Date and Time	59
Using the Color Palettes	60
Setting the Reference Colors.....	61
Setting Math Colors	61
Using MultiView Zoom	61
Zooming in Multiple Areas	63
Lock and Scroll Zoomed Waveforms.....	65
Hide Waveforms in the Zoomed Window	66
Searching and Marking Waveforms	66
Analyzing Waveforms	77
Taking Automatic Measurements.....	77
Automated Measurement Selections.....	79
Customizing an Automatic Measurement	81
Taking Cursor Measurements	85
Setting Up a Histogram	88
Using Math Waveforms	90
Using Spectral Analysis.....	92
Using Mask Testing	95
Using Limit Testing	98
MyScope	101
Creating a New MyScope Control Window	101
Using MyScope Control Windows.....	105
Saving and Recalling Information.....	107
Saving Screen Captures	107
Saving Waveforms	108
Recalling Waveforms	110
Saving Instrument Setups	111
Recalling Instrument Setups.....	112
Saving Measurements	113
Copying Your Results to the Clipboard.....	114
Printing a Hard Copy.....	116

Run Application Software	117
Application Examples	119
Capturing Intermittent Anomalies	119
Using the Extended Desktop and OpenChoice Architecture for Efficient Documentation	123
Triggering on Buses	125
Triggering on a Video Signal	126
Setting Up E-mail on Event	128
Correlating Data Between a Tektronix Oscilloscope and Logic Analyzer	130
Verifying Performance Using Limit Test	131
Cleaning	134
Index	

General Safety Summary

Review the following safety precautions to avoid injury and prevent damage to this product or any products connected to it.

To avoid potential hazards, use this product only as specified.

Only qualified personnel should perform service procedures.

While using this product, you may need to access other parts of a larger system. Read the safety sections of the other component manuals for warnings and cautions related to operating the system.

To Avoid Fire or Personal Injury

Use Proper Power Cord. Use only the power cord specified for this product and certified for the country of use.

Connect and Disconnect Properly. Do not connect or disconnect probes or test leads while they are connected to a voltage source.

Ground the Product. This product is grounded through the grounding conductor of the power cord. To avoid electric shock, the grounding conductor must be connected to earth ground. Before making connections to the input or output terminals of the product, ensure that the product is properly grounded.

Observe All Terminal Ratings. To avoid fire or shock hazard, observe all ratings and markings on the product. Consult the product manual for further ratings information before making connections to the product.

The inputs are not rated for connection to mains or Category II, III, or IV circuits.

Connect the probe reference lead to earth ground only.

Power Disconnect. The power cord disconnects the product from the power source. Do not block the power cord; it must remain accessible to the user at all times.

Do Not Operate Without Covers. Do not operate this product with covers or panels removed.

Do Not Operate With Suspected Failures. If you suspect that there is damage to this product, have it inspected by qualified service personnel.

Avoid Exposed Circuitry. Do not touch exposed connections and components when power is present.

Do Not Operate in Wet/Damp Conditions.

Do Not Operate in an Explosive Atmosphere.

Keep Product Surfaces Clean and Dry.

Provide Proper Ventilation. Refer to the manual's installation instructions for details on installing the product so it has proper ventilation.

Terms in this Manual

These terms may appear in this manual:



WARNING. *Warning statements identify conditions or practices that could result in injury or loss of life.*



CAUTION. *Caution statements identify conditions or practices that could result in damage to this product or other property.*

Symbols and Terms on the Product

These terms may appear on the product:

- DANGER indicates an injury hazard immediately accessible as you read the marking.
- WARNING indicates an injury hazard not immediately accessible as you read the marking.
- CAUTION indicates a hazard to property including the product.

The following symbol(s) may appear on the product:



Environmental Considerations

This section provides information about the environmental impact of the product.

Product End-of-Life Handling

Observe the following guidelines when recycling an instrument or component:

Equipment Recycling. Production of this equipment required the extraction and use of natural resources. The equipment may contain substances that could be harmful to the environment or human health if improperly handled at the product's end of life. In order to avoid release of such substances into the environment and to reduce the use of natural resources, we encourage you to recycle this product in an appropriate system that will ensure that most of the materials are reused or recycled appropriately.



This symbol indicates that this product complies with the European Union's requirements according to Directive 2002/96/EC on waste electrical and electronic equipment (WEEE). For information about recycling options, check the Support/Service section of the Tektronix Web site (www.tektronix.com).

Mercury Notification. This product uses an LCD backlight lamp that contains mercury. Disposal may be regulated due to environmental considerations. Please contact your local authorities or, within the United States, the Electronics Industries Alliance (www.eiae.org) for disposal or recycling information.

Perchlorate Materials. This product contains one or more type CR lithium coin cell batteries. According to the state of California, CR lithium coin cells are classified as perchlorate materials and require special handling. See www.dtsc.ca.gov/hazardouswaste/perchlorate for additional information.

Restriction of Hazardous Substances

This product has been classified as Monitoring and Control equipment, and is outside the scope of the 2002/95/EC RoHS Directive.

Preface

This manual describes the installation and operation of DPO7000 Series, DSA7000 Series and DPO70000 Series Instruments. Basic operations and concepts are presented in this manual. For more detailed information see the online help on your instrument. The following instruments are supported by this manual:

- DPO72004 and DSA72004
- DPO71604 and DSA71604
- DPO71254 and DSA71254
- DPO70804 and DSA70804
- DPO70604 and DSA70604
- DPO70404 and DSA70404
- DPO7354
- DPO7254
- DPO7104
- DPO7054

Key Features

DPO7000, DSA70000 and DPO70000 Series Instruments can help you verify, debug, and characterize electronic designs. Key features include:

- 20 GHz bandwidth and 50 GS/s real time sampling rate on all channels, DPO72004 and DSA72004
- 16 GHz bandwidth and 50 GS/s real time sampling rate on all channels, DPO71604 and DSA71604
- 12.5 GHz bandwidth and 50 GS/s real time sampling rate on all channels, DPO71254 and DSA71254
- 8 GHz bandwidth and 25 GS/s real time sampling rate on all channels, DPO70804 and DSA70804
- 6 GHz bandwidth and 25 GS/s real time sampling rate on all channels, DPO70604 and DSA70604
- 4 GHz bandwidth and 25 GS/s real time sampling rate on all channels, DPO70404 and DSA70404
- 3.5 GHz bandwidth and 10 GS/s real time sampling rate on all channels, 40 GS/s on 1 channel, DPO7354
- 2.5 GHz bandwidth and 10 GS/s real time sampling rate on all channels, 40 GS/s on 1 channel, DPO7254
- 1 GHz bandwidth and 5 GS/s (10 GS/s optional) real time sampling rate on all channels, 20 GS/s (40 GS/s optional) on 1 channel, DPO7104
- 500 MHz bandwidth and 2.5 GS/s (5 GS/s optional) real time sampling rate on all channels, 10 GS/s (20 GS/s optional) on 1 channel, DPO7054
- Enhanced Bandwidth capability that, when enabled, applies Digital Signal Process (DSP) filters that can extend the bandwidth and flatten the passband. Enhanced Bandwidth provides a matched response across enabled channels when they are at maximum sample rate. You can limit the bandwidth in 1 GHz increments down to 500 MHz for maximum bandwidth to optimize the signal to noise ratio. Enhanced bandwidth is extended to the probe tip for some high performance probes and tips.

- Record lengths up to 400,000,000 samples, depending on model and option
- Up to 1.0% DC vertical gain accuracy, depending on model
- Four input channels (each with 8-bit resolution when not in Hi-Res mode), auxiliary trigger input and output
- Sample, envelope, peak-detect, high-resolution, waveform database, average, and FastAcq acquisition modes
- Full programmability, with an extensive GPIB-command set and a message-based interface
- Trigger types include edge, logic, pulse (may be logic qualified), selectable for both A and B trigger events. Window trigger mode triggers as the trigger source passes into or out of a defined window. Triggers can be logic qualified. Setup and hold trigger mode triggers when a logic input changes state inside of the setup and hold times relative to the clock. Trigger jitter is less than 1 ps RMS (typical), depending on model. You can typically trigger on a glitch or pulse of less than 200 ps in width. Low speed serial triggering, serial pattern triggering, and pattern lock triggering are available on some models or options. Selectable trigger position correction to more accurately place the trigger and reduce jitter.
- Powerful built-in measurement capability, including histograms, automatic measurements, eye pattern measurements and measurement statistics
- Mathematically combine waveforms to create waveforms that support your data-analysis task. Use arbitrary filters in math equations. Use spectral analysis to analyze waveforms in the frequency domain.
- A large 12.1 inch (307.3 mm) high resolution XGA color display that supports color grading of waveform data to show sample density. Display 10 divisions both horizontally and vertically.
- MultiView Zoom to view and compare up to four zoom areas at a time. Lock and manually or automatically scroll up to four zoom areas. You can control the visibility of waveforms inside the zoom window
- Automatic event search and user marking to automatically find and refer to desired points of interest on your waveforms
- Automatic DDR analysis using the DDR Memory Technology Analysis option
- Customizable MyScope control windows
- Ability to control sample rate and record length separately from time per division
- An intuitive, graphical user interface (UI), with online help that is built in and available on screen
- Internal, removable disk storage
- Wide array of probing solutions

Documentation

Review the following for the location of different types of information available for this product.

To read about	Use these documents
Installation and Operation (overviews)	Quick Start User Manual. Provides general operating information.
In-Depth Operation and User Interface Help	Online Help. Provides detailed instructions for using instrument functions. Access online help from the Help button or Help menu for information on controls and elements on screen. (See page 17, <i>Accessing Online Help</i> .)
Programmer Commands	Programmer guide (on the product software CD). Includes the syntax of the GPIB commands.
Analysis and Connectivity Tools	Getting Started with OpenChoice Solutions Manual. Provides information about various connectivity and analysis tools available on your instrument.

Conventions Used in this Manual

The following icons are used throughout this manual.

Sequence Step



Front panel power



Connect power

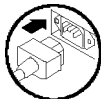

Network

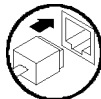

PS2

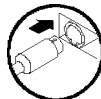

SVGA

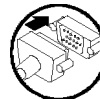

USB

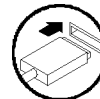

Install Your Instrument

Unpack the instrument and check that you received all items listed as Standard Accessories. Recommended accessories, probes, instrument options, and upgrades are listed in the online help. Check the Tektronix Web site (www.tektronix.com) for the most current information.

Standard Accessories

Accessory		Tektronix part number	
DPO7000, DSA70000 and DPO70000 Digital Phosphor Oscilloscopes Quick Start User Manual		071-1733-xx	
DPO7000, DSA70000 and DPO70000 Product Software CD		020-2693-xx	
Optional Applications Software CD and Documentation Kit		020-2700-xx	
Online Help (part of the product software)		—	
Performance Verification (a pdf file on the Product Software CD)		—	
Programmer Online Guide (files on the Product Software CD)		—	
NIST, Z540-1, and ISO9000 Calibration Certificate		—	
Four 10X passive probes, 500 MHz models, DPO7054 only		P6139A	
One TekConnect adapter, ≥ 4 GHz models only		TCA-BNC	
Four TekConnect adapters, ≥ 4 GHz models only		TCA-292MM	
Keyboard, ≥ 4 GHz models only		119-7083-xx	
Mouse, optical		119-7054-xx	
Front Cover		200-4963-xx	
Accessory Pouch		<4 GHz models: 016-1966-xx ≥ 4 GHz models: 016-1441-xx	
Probe Calibration and Deskew Fixture, with instructions		<4 GHz models: 067-0405-xx 4 GHz models: 067-0484-xx >4 GHz models: 067-1586-xx	
Nero OEM Software CD		063-3781-xx	
Power Cord	One of the following:	<4 GHz Models	≥ 4 GHz Models
	North America (Option A0)	161-0104-00	161-0213-00
	Universal Euro (Option A1)	161-0104-06	161-0209-00
	United Kingdom (Option A2)	161-0104-07	161-0210-00
	Australia (Option A3)	161-0104-05	161-0211-01
	Switzerland (Option A5)	161-0167-00	161-0212-00
	Japan (Option A6)	161-A005-00	161-0213-00
	China (Option A10)	161-0306-00	161-0320-00
	India (Option A11)	161-0324-00	161-0325-00
	No power cord or AC adapter (Option A99)	—	—

Operating Requirements

- Place the instrument on a cart or bench, observing clearance requirements and dimensions:

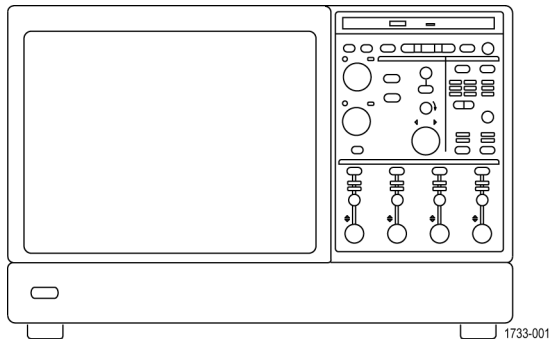

	<4 GHz Models	≥4 GHz Models
<ul style="list-style-type: none"> ■ Top: ■ Left and right side: ■ Bottom: ■ Rear: 	<p>0 in (0 mm)</p> <p>3 in (76 mm)</p> <p>0 in (0 mm) standing on feet, flip stands down</p> <p>0 in (0 mm) on rear feet</p>	<p>0 in (0 mm)</p> <p>3 in (76 mm)</p> <p>0 in (0 mm) standing on feet, flip stands down</p> <p>0 in (0 mm) on rear feet</p>
2. Width:	17.96 inches (456 mm)	17.75 inches (451 mm)
3. Height:	10.9 inches (277 mm)	11.48 inches (292 mm)
4. Before operating the instrument, verify the ambient temperature:	5 °C to +45 °C (+41 °F to +113 °F)	5 °C to +45 °C (+41 °F to +113 °F)
5. Verify the operating humidity:	<p>8% to 80% relative humidity with a maximum wet-bulb temperature of +29 °C (+84 °F) at or below +45 °C (+113 °F), noncondensing</p> <p>Upper limit derated to 30% relative humidity at +45 °C (+113 °F)</p>	<p>8% to 80% relative humidity at up to +32 °C (+90 °F)</p> <p>5% to 45% relative humidity above +32 °C (+90 °F) up to +45 °C (+113 °F), noncondensing, and is limited by a maximum wet-bulb temperature of +29.4 °C (+85 °F) (derates relative humidity to 32% at +45 °C (+113 °F))</p>
6. Verify the operating altitude:	<p><4 GHz models: 3,000 m (9,843 feet)</p>	<p>≥4 GHz models: 3,000 m (9,843 feet), derate maximum operating temperature by 1 °C per 300 meters (984.25 feet) above 1500 meters (4921.25 feet) altitude.</p>
7. Maximum input voltage, <4 GHz models:	<p>50 Ω</p> <p>1 MΩ</p>	<p>5 V_{rms}, with peaks ≤±24 V.</p> <p>150 V, derate at 20 dB/decade to 9 V_{rms} above 200 KHz. The maximum input voltage at the BNC, between center conductor and ground is 400 V peak. The RMS voltage is limited to <150 V for arbitrary waveshapes including DC. The maximum pulse width for impulses with peaks over 150 V is 50 (micro)s. Example: At 0 V to 400 V peak, rectangular wave, the duty factor is 14%. The maximum transient withstand voltage is ±800 V peak.</p>

Maximum input voltage, ≥ 4 GHz models:

50 Ω

$< 1 V_{\text{rms}}$ for $< 1\text{V}/\text{FS}$ settings and $< 5.5 V_{\text{rms}}$ for $\geq 1\text{V}/\text{FS}$ settings.



CAUTION. To ensure proper cooling, keep the bottom and sides of the instrument clear of obstructions.

Powering On the Instrument

Power Supply Requirements

Source Voltage and Frequency

<4 GHz models: 100–240 V_{RMS} ±10%, 47–63 Hz
or 115 V_{RMS} ±10%, 400 Hz

Power Consumption

550 Watts maximum

≥4 GHz models: 100–240 V_{RMS} ±10%, 50–60 Hz
or 115 V_{RMS} ±10%, 400 Hz. CAT II

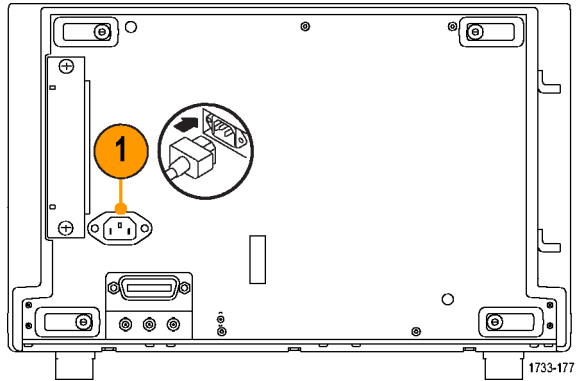

<4 GHz models

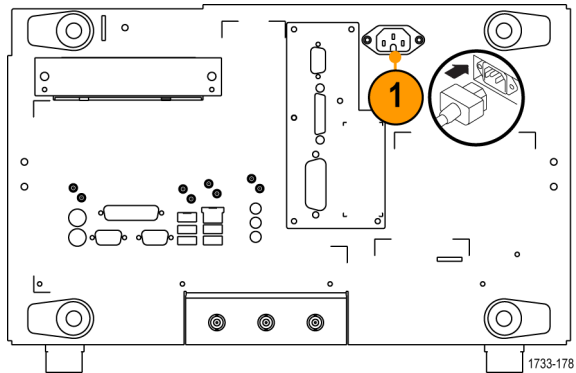

≥4 GHz models

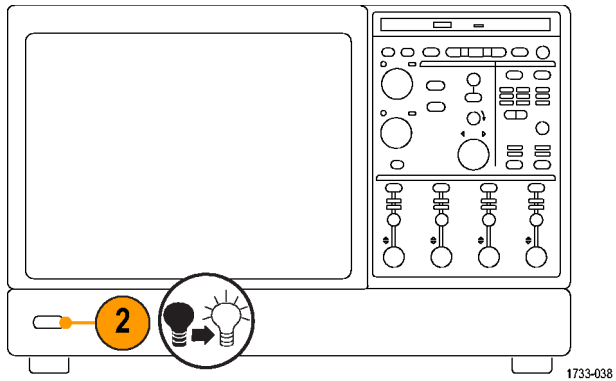

Powering Off the Instrument

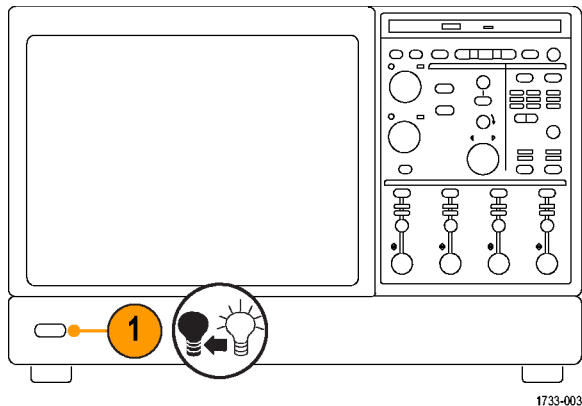

Removing the Power

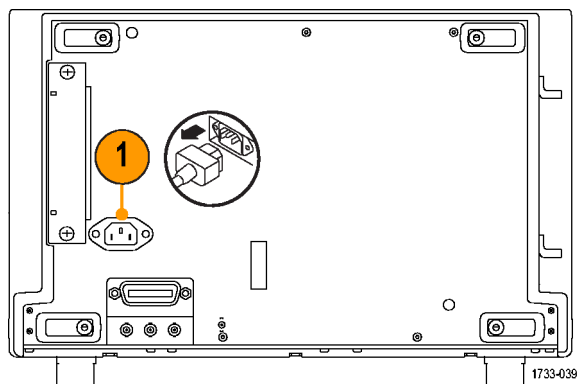

<4 GHz models

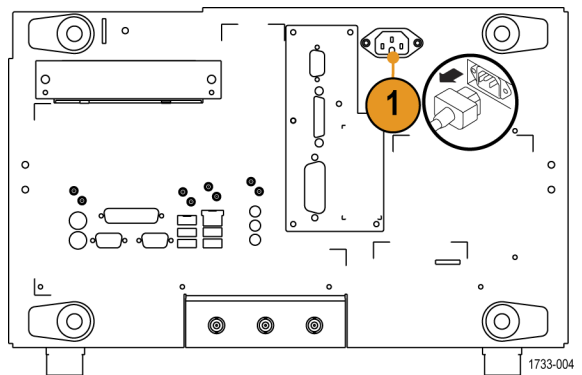

≥4 GHz models

Connecting to a Network

You can connect your instrument to a network for printing, file sharing, internet access, and other functions. Consult with your network administrator and use the standard Windows utilities to configure the instrument for your network.

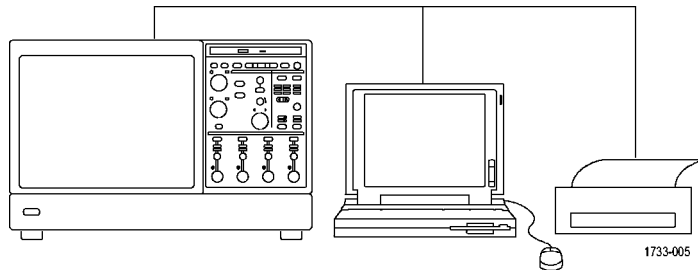

NOTE. For remote operation over the network, toggle *Display>Display Remote* on. VNC or *pcAnywhere* must be installed on the instrument and on the remote PC. When *Display Remote* is enabled, display updates, control window accessing and menu items are slow.

Adding a Second Monitor

You can operate the instrument while using Windows and installed applications on an external monitor. Follow the procedure below to set up a dual monitor configuration.

1. Turn off power.
2. Connect second monitor.

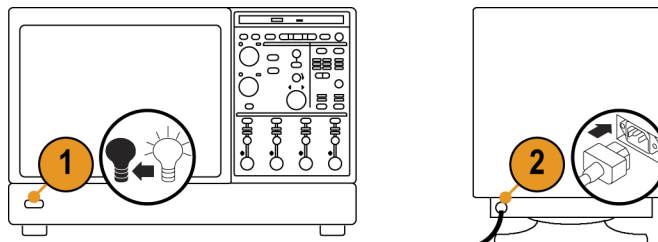

3. Connect keyboard.
4. Connect mouse.

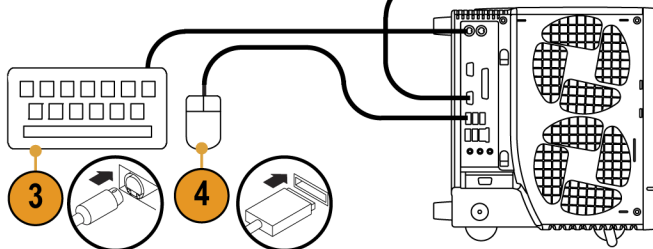

5. Turn on instrument power.
6. Turn on monitor power.

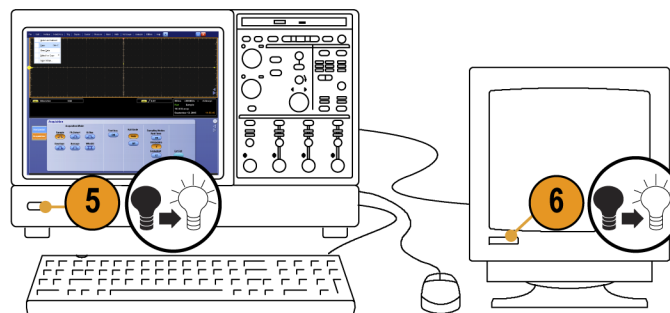

<4 GHz models

1733-006

1. Turn power off.
2. Connect second monitor.

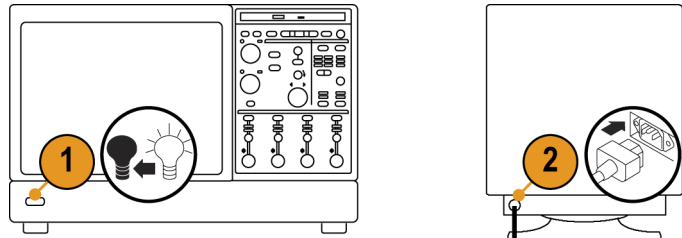

3. Connect keyboard.
4. Connect mouse.

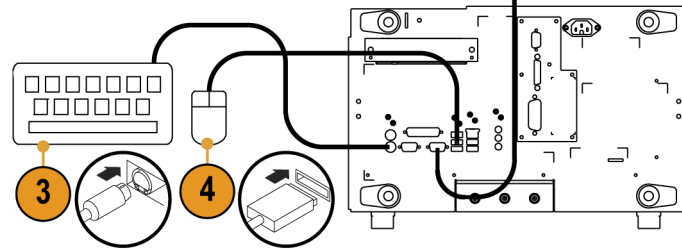

5. Turn instrument power on.
6. Turn monitor power on.

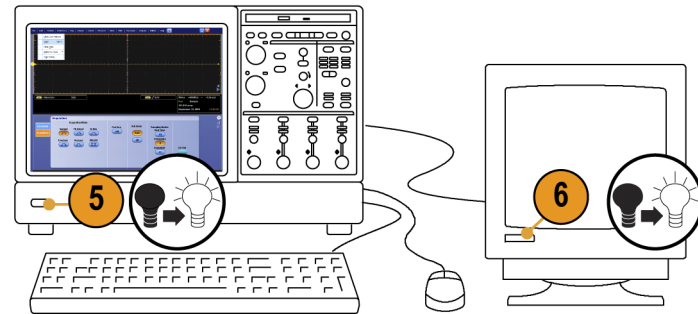

≥4 GHz models

1733-040

- Right-click on the Windows desktop, and then select **Properties**.

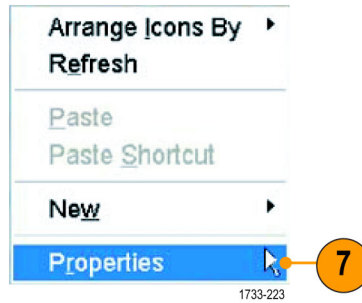

- Select **Settings**. Click the grayed out external monitor (2), and drag it to the left of monitor 1.
- Select **Yes** when you are prompted to enable the new monitor.
- Click **Apply**.

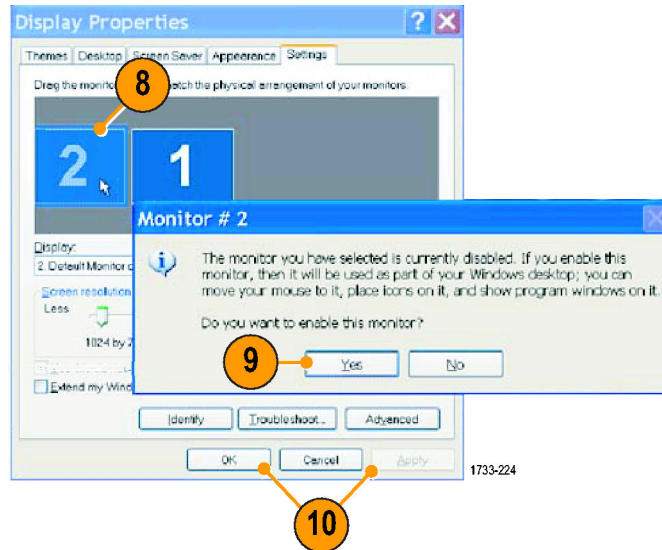

- Click **Yes** to restart your instrument.



Creating Operating System Restore CD-ROMs

The instrument does not ship with an operating system restore DVD. Use the following procedure to create a set of CD-ROMs that enable you to restore the operating system if the need arises.

NOTE. *This procedure creates a set of restore CD-ROMs for the Microsoft Windows operating system. After restoring the operating system, use the Product Software CD to reinstall the instrument application software. Follow the instructions supplied with the Product Software CD to reinstall the instrument application software.*

Creating Restore CD-ROMs

Prerequisite. Blank CD-R discs (one for each backup file).

To create a set of restore CD-ROMs:

1. Insert a blank CD-R in the instrument DVD drive.
2. Click Start > All Programs > Nero 7 Essentials > Data > Nero Express Essentials.
3. Click Image, Project, Copy.
4. Click Disk Image or Saved Project.
5. Navigate to C:\backup.
6. Select file backup1 and click Open.
7. Click the Verify data on disk after burning check box to enable this function.
8. Click the Burn button. The application writes the backup file to the CD-R and then verifies that the data on the CD matches the source file.
9. When the application reports that the CD write process has completed successfully, remove the CD-R and label it accordingly (include backup file name, instrument name, instrument serial number, and date).
10. Repeat steps 1 through 9 for each of the remaining backup files.
11. Copy the disk image files (*.iso) located in the C:\backup directory to a network location, a separate hard disk, or optical media for backup purposes.
12. Store the backup CDs as defined by your company policy.

NOTE. *Operating system restore discs can only be used on the instrument from which they were created.*



Getting Acquainted with Your Instrument

Front Panel

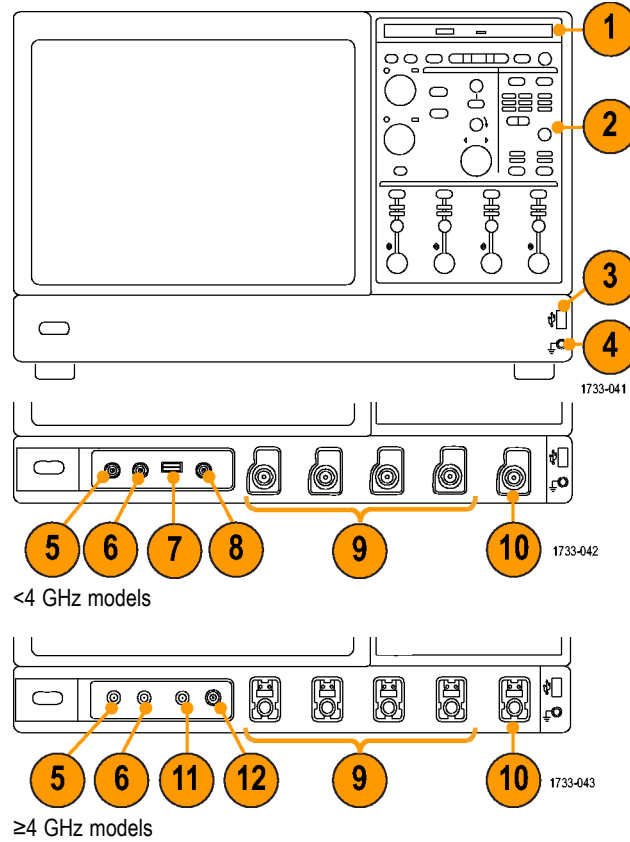
1. DVD/CD-RW drive
2. Front panel controls
3. USB port
4. Ground terminal
5. Recovered data output
6. Recovered clock output
7. Probe compensation output
8. Probe calibration output
9. Channel 1–4 input
10. Auxiliary Trigger input
11. Fast Edge output
12. DC Probe Cal output



Side and Rear Panels

1. USB ports
2. Video port to connect a monitor for side-by-side display
- NOTE. Some instruments may have additional audio connectors.*
3. Mic connector for microphone
4. Line Out connector for speaker
5. Scope Only XGA Out video port to connect a monitor
6. Printer connection
7. Line In connector
8. RJ-45 LAN connector to connect to network
9. Centronics Parallel Port
10. COM 1 serial port
11.  PS-2 connector for mouse
12.  PS-2 connector for keyboard
13. TekLink connector for future use
14. Removable hard disk drive
15. GPIB port to connect to controller
16. Auxiliary output
17. Channel 3 output
18. External reference input

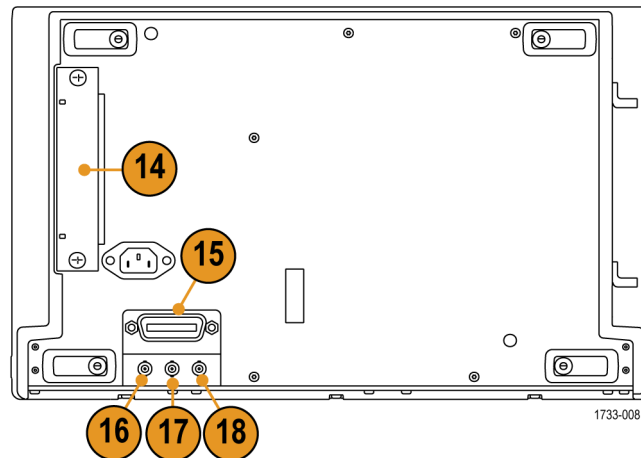
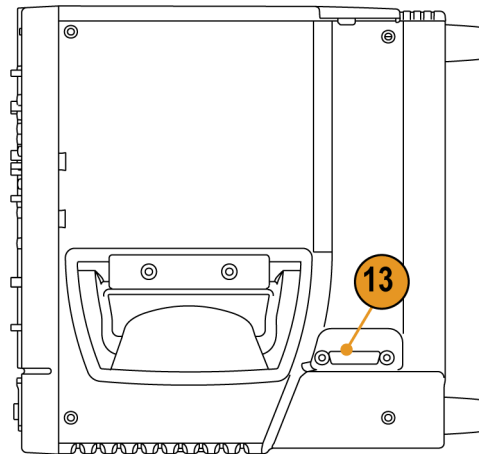
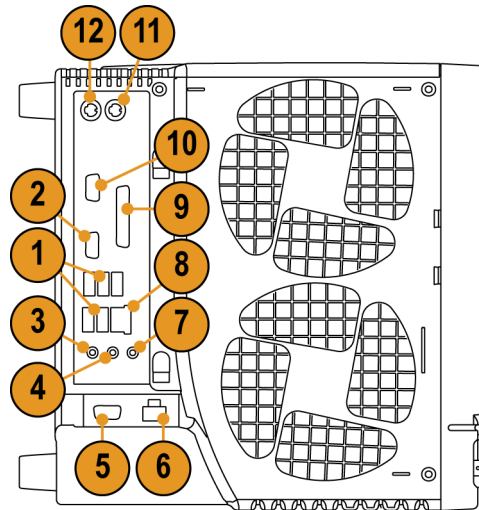

<4 GHz models

1733-008

1. Removable hard disk drive
2. PS-2 connector for mouse
3. USB ports
4. Centronics Parallel Port
5. RJ-45 LAN connector to connect to network
6. Video port to connect a monitor
7. TekLink connector
8. GPIB port to connect to controller

NOTE. Some instruments may have additional audio connectors.

9. Line In connector
10. Line Out connector for speaker
11. Mic connector for microphone
12. Video port to connect a monitor for side-by-side display
13. COM 1 serial port
14. PS-2 connector for keyboard
15. Auxiliary output
16. Reference output
17. External reference input

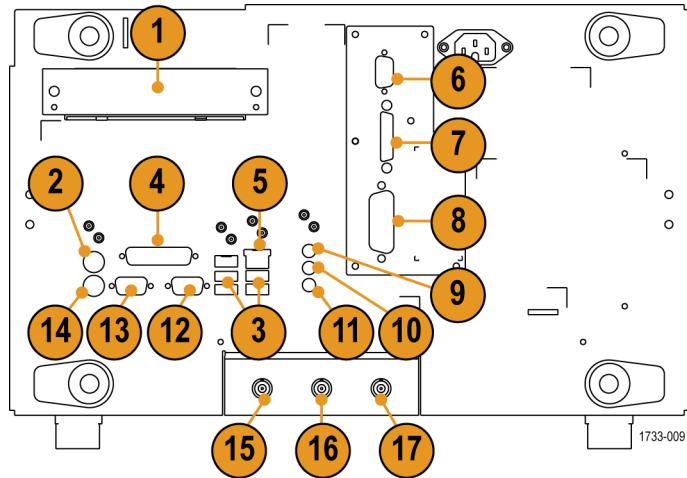

≥4 GHz models

Interface and Display

The menu bar mode provides access to commands that control all of the instrument features and functions. The toolbar mode provides access to the most common features.

1. **Menu Bar:** Access to data I/O, printing, online help, and instrument functions
2. **Buttons/Menu:** Click to toggle between toolbar and menu bar modes and to customize your toolbar
3. **Multipurpose Knob Readouts:** Adjust and display parameters controlled by the multipurpose knobs
4. **Display:** Live, reference, and math waveforms display here, along with cursors
5. **Waveform Handle:** Click and drag to change vertical position of waveform. Click the handle and change the position and scale using the multipurpose knobs.
6. **Controls Status:** Quick reference to vertical selections, scale, offset, and parameters
7. **Readouts:** Display cursor and measurement readouts in this area. Measurements are selectable from the menu bar or toolbar. If a control window is displayed, some combinations of readouts move to the graticule area.

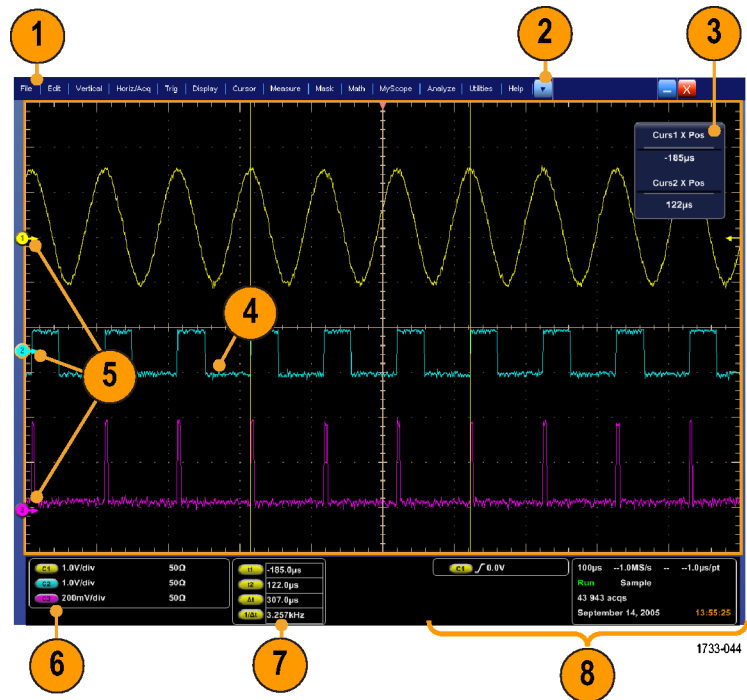

WARNING. If there is vertical clipping, there may be a dangerous voltage on the probe tip, but the readout will indicate a low voltage.

A  symbol appears in the measurement readout if a vertical clipping condition exists. Automatic amplitude-related measurements where the signal is vertically clipped produce inaccurate results. Clipping also causes inaccurate amplitude values in waveforms that are stored or exported for use in other programs. If a math waveform is clipped, it will not affect amplitude measurements on that math waveform.

8. **Status:** Display of acquisition status, mode, and number of acquisitions; trigger status; date; time; and quick reference to record length and horizontal parameters

1. **Buttons/Menu:** Click to toggle between toolbar and menu bar modes and to customize the toolbar
2. Drag cursors to measure waveforms on screen
3. Drag the position icons to reposition a waveform
4. Click the icon to assign the multipurpose knobs to waveform vertical position and scale
5. Drag across the waveform area to create a box for zooming, enabling/disabling histograms, and gating measurements
6. Drag icon to change the trigger level

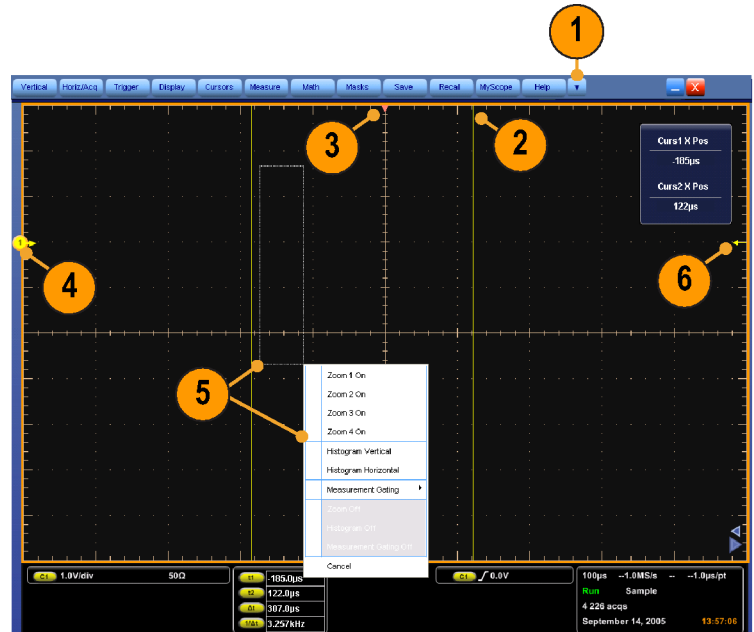

1733-045

Control Panel

1. Push to automatically set up the vertical, horizontal, and trigger controls based on selected channels.
2. Push to return settings to default values.
3. Push to make a hard copy or save a screen capture.
4. Push to turn on MultiView Zoom and add a magnified graticule to the display.
5. Horizontally scale, position, delay, and set record length (resolution) of all waveforms.
6. Use to start and stop acquisition, start a single acquisition sequence, clear data, or start fast acquisitions.
7. Use to set the trigger parameters. Push Advanced to display additional trigger functions. The Arm, Ready, and Trig'D lights show the acquisition status.
8. Turn to adjust waveform intensity.
9. Turn to adjust parameters selected from the screen interface. Push to toggle between normal and fine adjustment.
10. Push to turn cursors on or off.
11. Push to turn the touch screen on and off.
12. Turn channel displays on and off. Vertically scale, position, or offset the waveform. Toggle between position and offset.

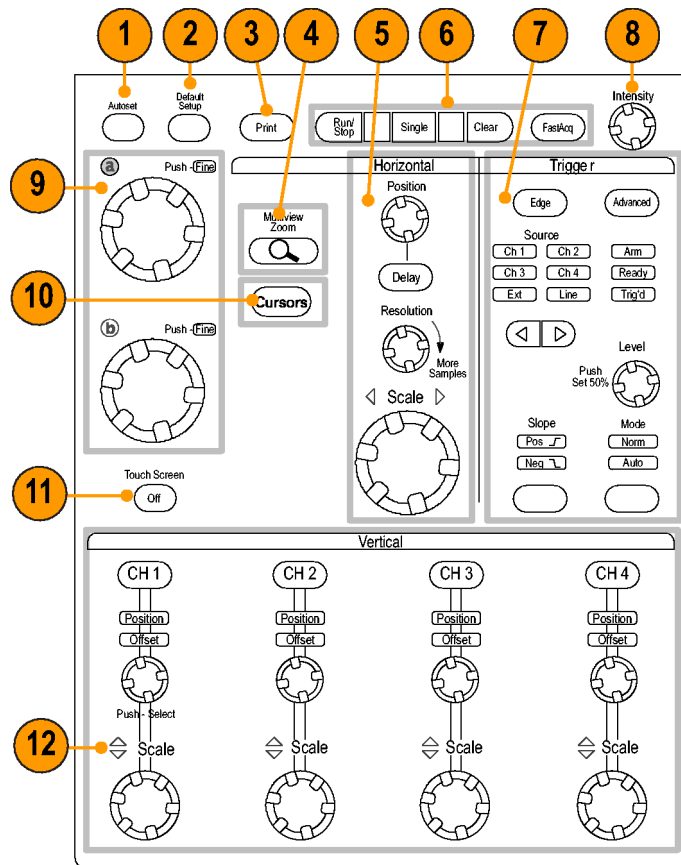

1733-011

Accessing Online Help

In-depth information is available in the online help on all the features of your instrument.

To access context-sensitive help on the active window, select **Help > Help on Window...** or press **F1**.

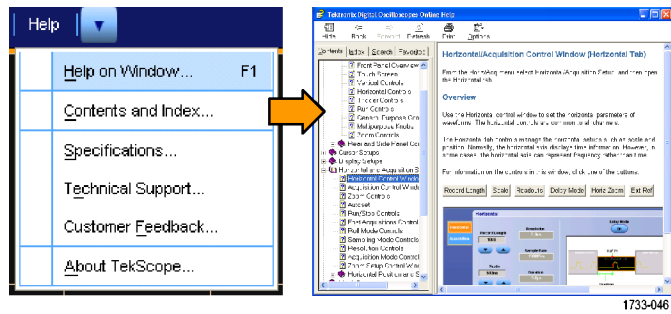

1733-046

1. To access any topic in the help system, select **Help > Contents and Index...**
2. Use the Contents, Index, Search, or Favorites tab to select the topic, and then click **Display**.

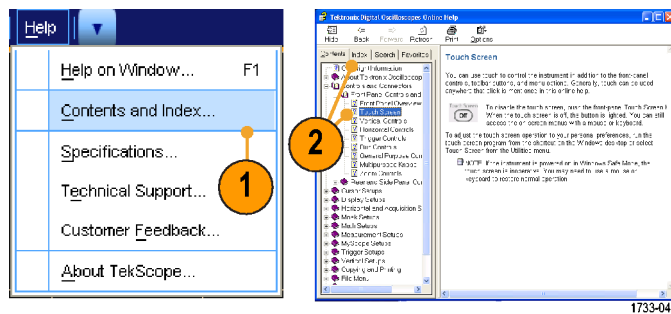

1733-047

To navigate within the help system you can:

- Click a button in a help window to navigate between the Overview and specific topics.
- Click the **Minimize** button in the help window to move help out of the way so you can operate the instrument.
- Click **Alt** and **Tab** to see the last help topic again.

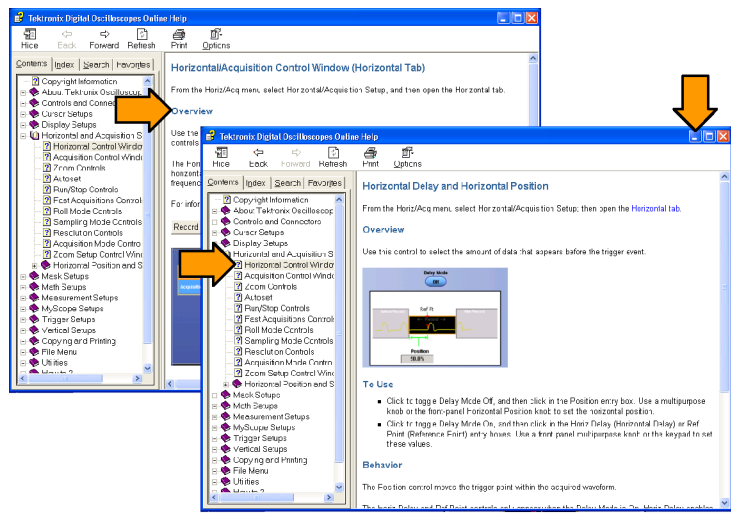

1733-048

Accessing Menus and Control Windows

You can access menus and control windows using the following techniques:

- Click a menu, and then select a command.

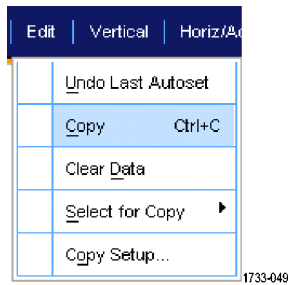

- For a shortcut menu, right-click anywhere in the graticule or on an object. The shortcut menu is context sensitive and varies with the area or object where you right-clicked. Some examples are shown in the figure at right.

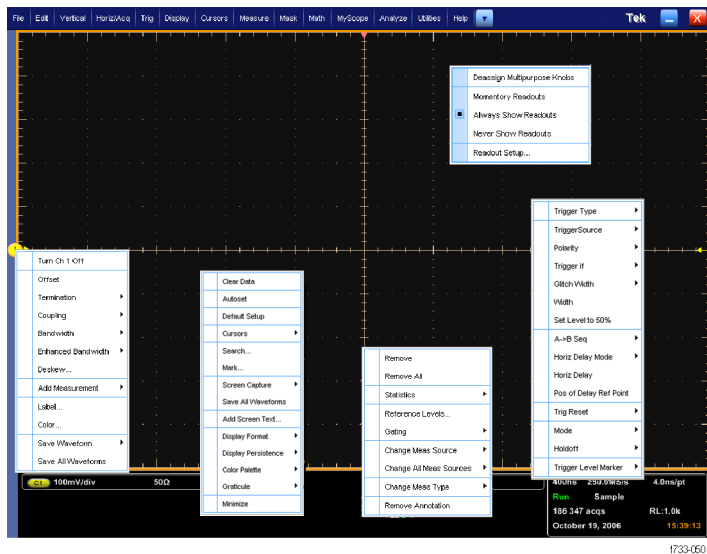

- In the toolbar mode, click a button to quickly access a setup control window. (See page 13.)



Inspect Your Instrument

Use the following procedures to verify the functionality of your instrument.

Verify Internal Diagnostics Pass

1. Power on the instrument.

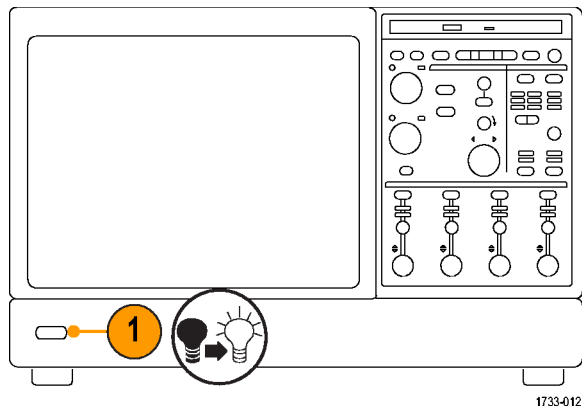

2. Select Instrument Diagnostics....

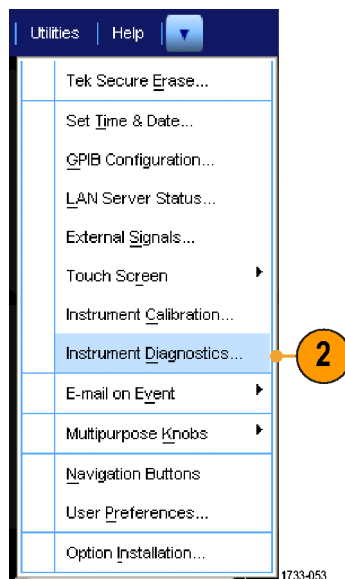

3. Click **Run**. The test results appear in the diagnostics control window.
4. Verify that all tests pass. If diagnostic failures occur, contact your local Tektronix service personnel.

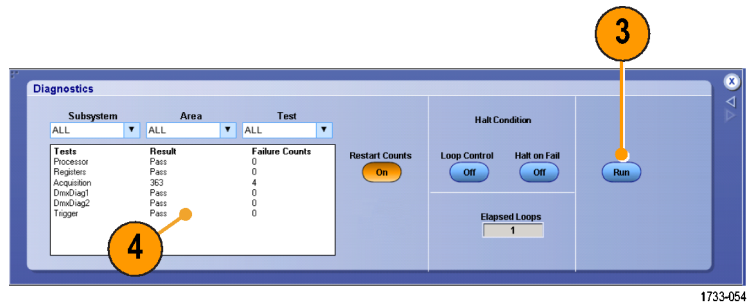

1733-054

Signal Path Compensation

Use this procedure if the temperature has changed more than 5 °C (9 °F) since the last signal path compensation. Perform the signal path compensation once a week. Failure to do so may result in the instrument not meeting warranted performance levels.

1. Prerequisites: instrument powered on for 20 minutes, and all input signals removed.

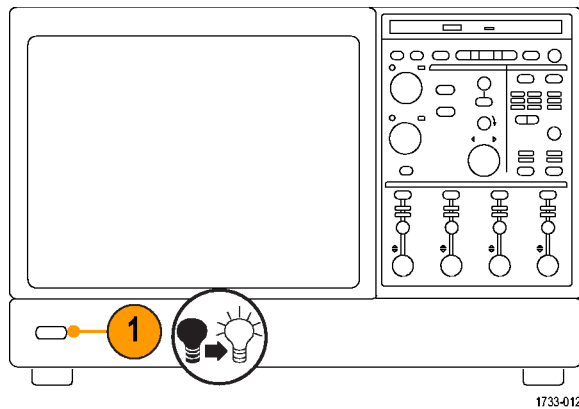

1733-012

2. Select **Instrument Calibration**.

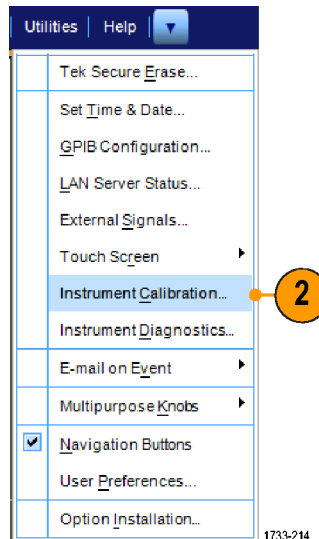

1733-214

- When the status changes to Temp, click Calibrate to start the calibration. Calibration may take 10 to 15 minutes.

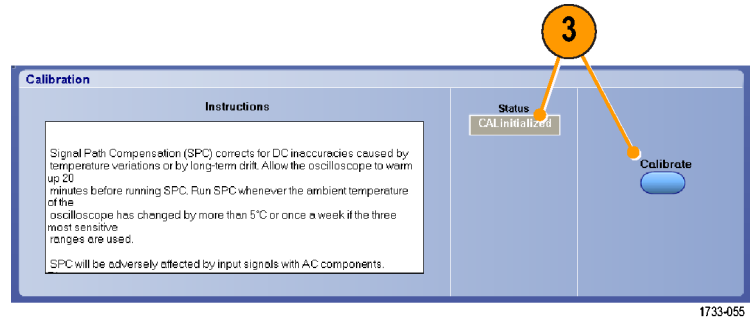

- If the instrument does not pass, recalibrate the instrument, or have the instrument serviced by qualified service personnel.

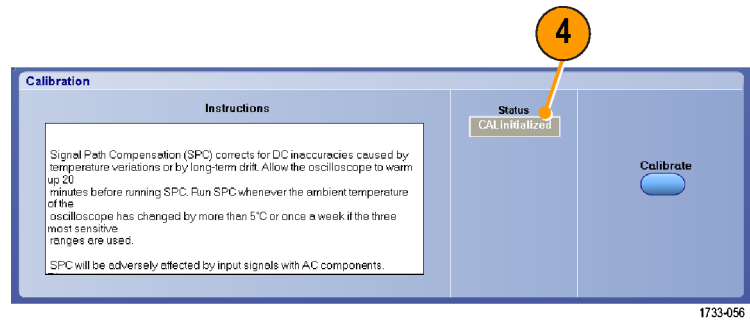

Acquisition

This section contains concepts of and procedures for using the acquisition system.

Setting Up Signal Input

Use front-panel buttons to set up your instrument to acquire the signal.

1. Connect the probe to the input signal source.

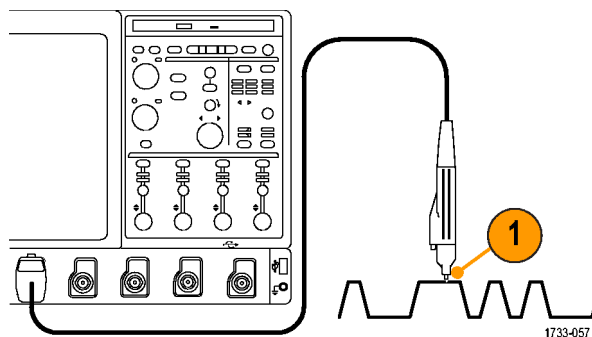

<4 GHz models

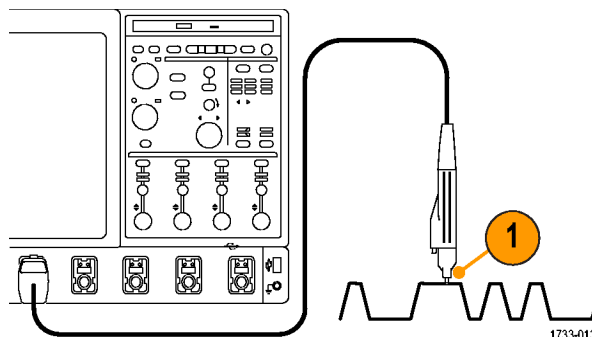

≥4 GHz models

2. Select the input channel by pushing the front-panel buttons to toggle the channels on and off.

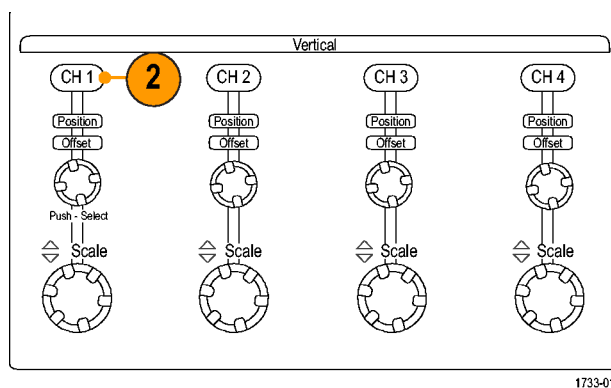

3. Press **Autoset**.
4. Adjust the vertical position, scale, and offset using the front-panel knobs. (Push the knob to toggle between position and offset.)

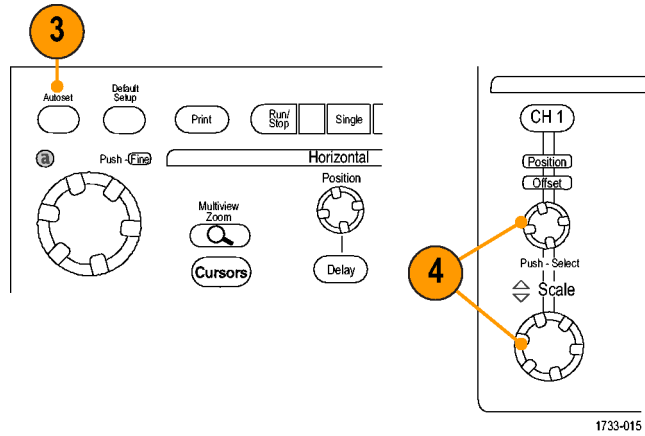

5. Adjust the horizontal position and scale using the front-panel knobs. The horizontal position determines the number of pretrigger and posttrigger samples.

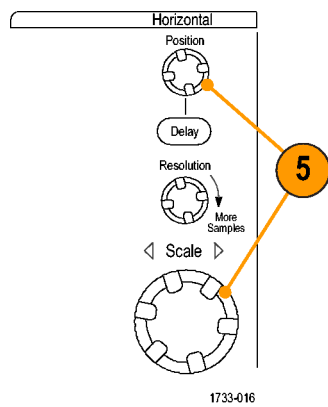

Using Default Setup

1. To quickly return to the factory default settings, push **DEFAULT SETUP**.

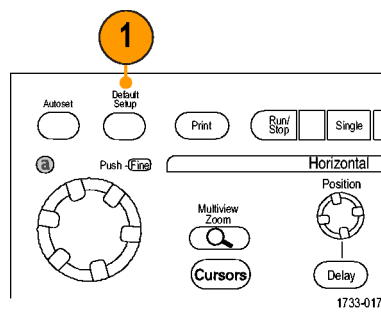

Using Autoset

Use Autoset to quickly and automatically set up the instrument (acquisition, horizontal, trigger, and vertical) based on the characteristics of the input signal. Autoset makes adjustments to the signal such that the waveform displays two or three cycles with the trigger level near the midlevel.

1. Connect the probe, and then select the input channel. (See page 23, *Setting Up Signal Input*.)
2. Push the **AUTOSET** button to execute an Autoset.

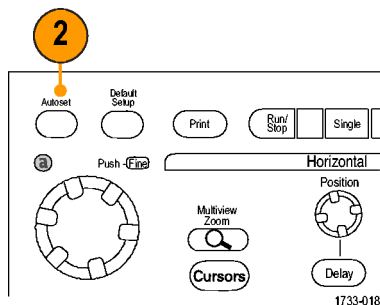

3. Click **Undo** if you want to undo the last Autoset. Parameters that are not affected by Autoset retain their settings.

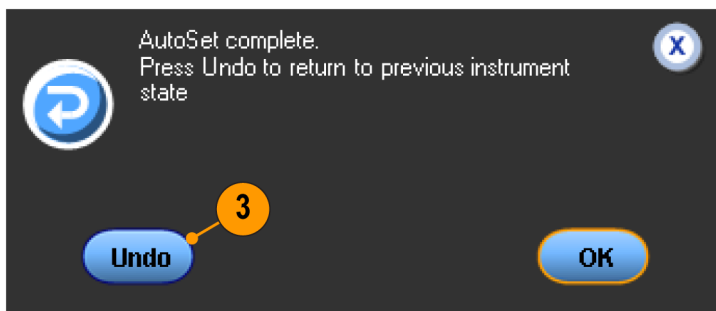

Quick Tips

- To position the waveform appropriately, Autoset may change the vertical position. Autoset may also adjust vertical offset.
- If you use Autoset when one or more channels are displayed, the instrument selects the lowest numbered channel for horizontal scaling and triggering. You can individually control the vertical scaling of each channel.
- If you use Autoset when no channels are displayed, the instrument turns on channel one (Ch 1) and scales it.
- Close Autoset Undo control window by clicking the X. After Autoset Undo closes, you can still undo the last Autoset by selecting the Undo Last Autoset command from the Edit menu.
- You can stop the Autoset Undo control window from opening automatically by changing the User Preferences in the Utilities menu.

Probe Compensation, Calibration, and Deskew

To optimize measurement accuracy, see the instrument online help to perform the following procedures:

- Compensate passive probes
- Compensate the instrument signal path
- Calibrate active probes
- Deskew input channels

Acquisition Concepts

Acquisition Hardware

Before a signal can be displayed, it must pass through the input channel where it is scaled and digitized. Each channel has a dedicated input amplifier and digitizer. Each channel produces a stream of digital data from which the instrument extracts waveform records.

Sampling Process

Acquisition is the process of sampling an analog signal, converting it into digital data, and assembling it into a waveform record, which is then stored in acquisition memory.

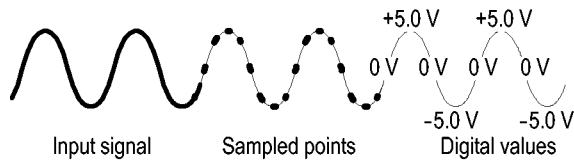

Real-Time Sampling

In real-time sampling, the instrument digitizes all of the points it acquires using one trigger event. Use real-time sampling to capture single-shot or transient events.

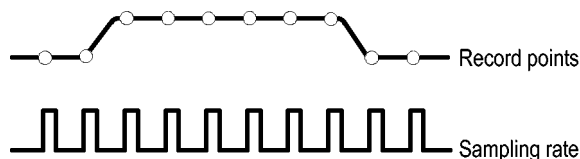

Interpolated Real-Time Sampling

In interpolated real-time sampling, the instrument digitizes all of the points it acquires using one trigger event. If the instrument cannot acquire enough samples for a complete waveform at the maximum real-time sample rate, it interpolates. Use interpolated real-time sampling to capture single-shot, transient events, or slow acquisitions.

Equivalent-Time Sampling

The instrument uses equivalent-time sampling to extend its sample rate beyond its real-time maximum sampling rate. Equivalent-time sampling is only used if Equivalent Time is selected and the time base is set to a sampling rate that is too fast to create a waveform record using real-time sampling.

The instrument makes multiple acquisitions of a repetitive waveform to obtain the sample density required for one complete waveform record. Thus, equivalent time sampling should only be used with repetitive signals.

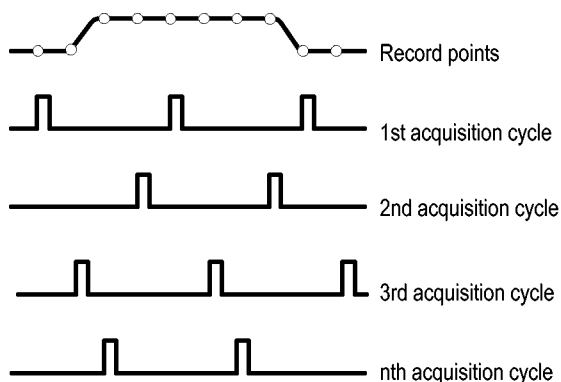

Waveform Record

The instrument builds the waveform record through use of the following parameters:

- **Sample interval:** The time between sample points.
- **Record length:** The number of samples required to fill a waveform record.
- **Trigger point:** The zero time reference in a waveform record.
- **Horizontal position:** When horizontal delay is off, the horizontal position is a percentage of the waveform record between 0 and 99.9 percent. The trigger point and the horizontal reference are at the same time in the waveform record. For example, if the horizontal position is 50 percent, then the trigger point is in the middle of the waveform record. When horizontal delay is on, the time from the trigger point to the horizontal reference is the horizontal delay.

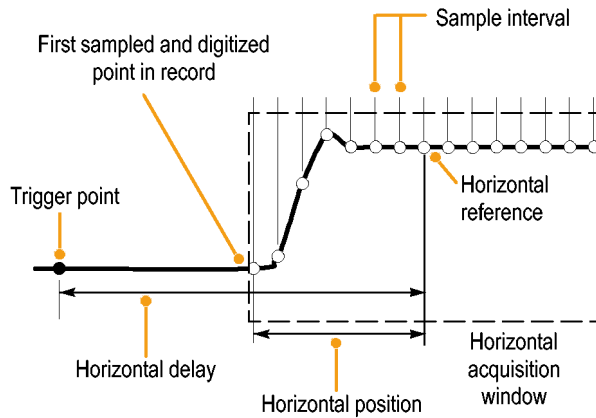

Interpolation

Your instrument can interpolate between the samples it acquires when it does not have all of the actual samples it needs to fill the waveform record. Linear interpolation computes record points between actual acquired samples by using a straight line fit.

Sin(x)/x interpolation computes record points using a curve fit between the actual values acquired. Sin(x)/x interpolation is the default interpolation mode because it requires fewer actual sample points than linear interpolation to accurately represent the waveform.

How the Acquisition Modes Work

Sample mode retains the first sampled point from each acquisition interval. Sample is the default mode.

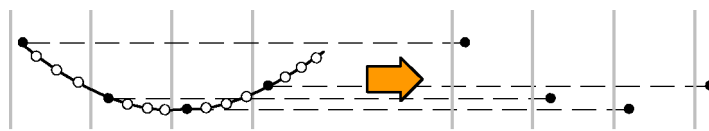

1733-210

Peak Detect mode uses the highest and lowest of all the samples contained in two consecutive acquisition intervals. This mode only works with real-time, noninterpolated sampling and is useful for catching high frequency glitches.

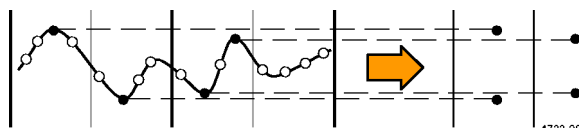

1733-207

Hi Res mode calculates the average of all the samples for each acquisition interval. Hi-Res provides a higher-resolution, lower-bandwidth waveform.

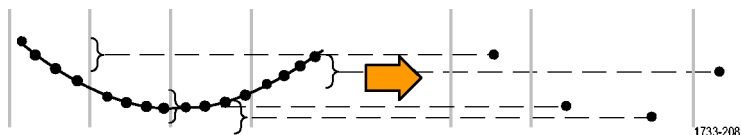

Envelope mode finds the highest and lowest record points over many acquisitions. Envelope uses Peak Detect for each individual acquisition.



Average mode calculates the average value for each record point over many acquisitions. Average uses Sample mode for each individual acquisition. Use average mode to reduce random noise.

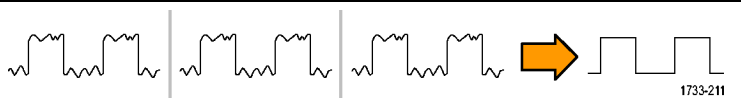

Waveform Database mode is a three-dimensional accumulation of source waveform data over several acquisitions. In addition to amplitude and timing information, the database includes a count of the number of times a specific waveform point (time and amplitude) has been acquired.



Changing the Acquisition Mode

Use this procedure to change the acquisition mode.

1. Select **Horiz/Acq > Acquisition Mode**.
2. To select an acquisition mode, do one of the following:
 - Select an acquisition mode directly from the menu.
 - Click **Mode...**, and then select an acquisition mode.

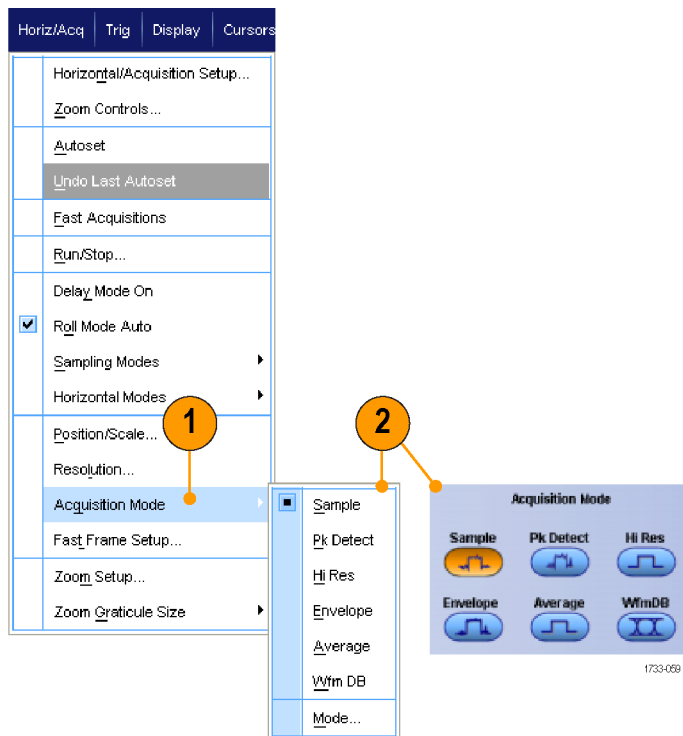

3. For Average or Envelope acquisition modes, click the **# of Wfms** control, and then set the number of waveforms with the multipurpose knob. For WfmDB mode, click the **Samples** control, and then set the number of samples with the multipurpose knob.

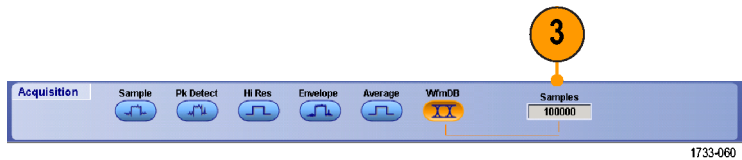

Quick Tip

- Click the keypad icon to set the number of waveforms or samples.

Starting and Stopping an Acquisition

After the channels that you want to acquire are selected, use the following procedure.

1. Press the front-panel **RUN/STOP** button to start the acquisition.
2. Press the **RUN/STOP** button again to stop the acquisition.
3. To take a single acquisition, press the **Single** button.

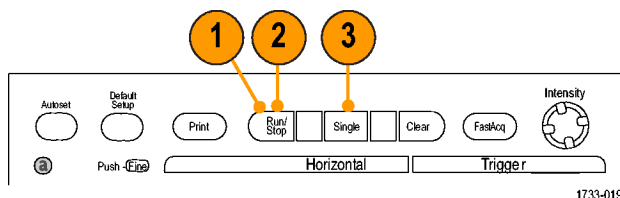

Selecting the Horizontal Mode

Your instrument has three horizontal modes. Automatic is the default mode. Select the horizontal mode that works best for your test setup.

To set the horizontal mode, select **Horiz/Acq** > **Horizontal/Acquisition Setup** to display the horizontal control window. Choose one of the modes described below.

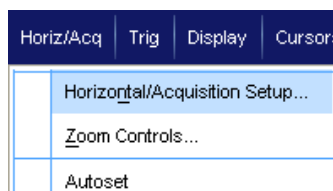

In Automatic mode you can set the Scale and Sample Rate. Record length is a dependent variable. If changing the scale would cause the record length to exceed the Record Length Limit, the sample rate is decreased to the next available setting.

If the sampling mode is real time and the sample rate is at the real time limit, attempting to increase the sample rate has no effect.

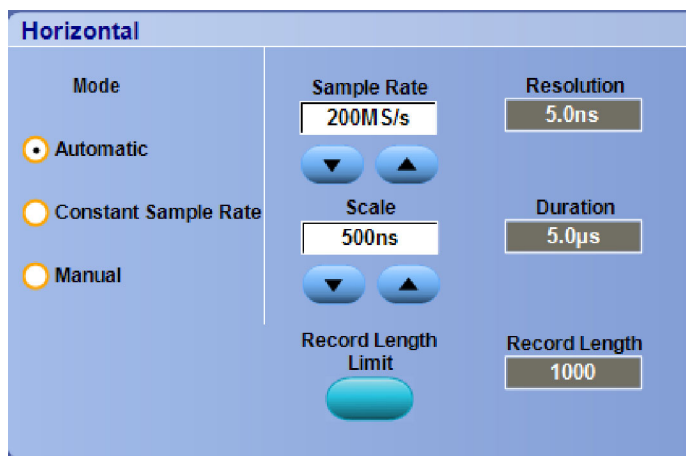

To set the Record Length Limit, click **Record Length Limit** and set the limit using the buttons or keypad. The default maximum limit depends on your instrument model and record length option.

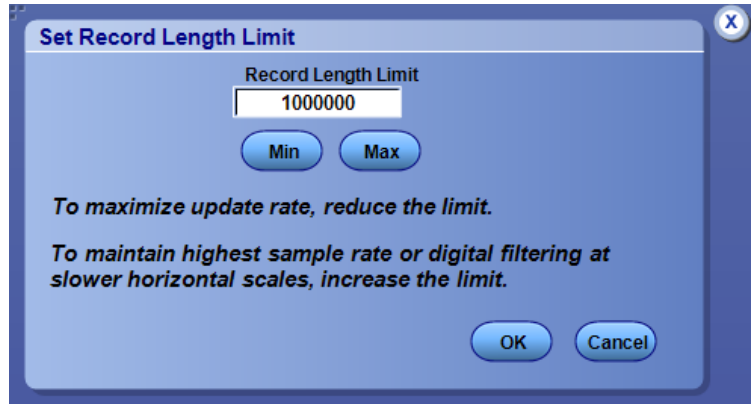

In Constant Sample Rate mode you can set the Sample Rate and Scale. The default sample rate ensures bandwidth filter operation. Record length is a dependent variable. The maximum record length depends on your instrument model and record length option.

The front-panel resolution knob changes the sample rate in both automatic and constant sample rate modes.

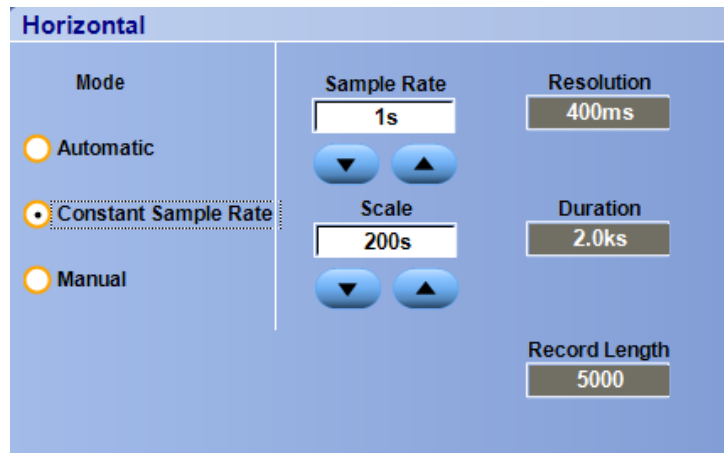

In Manual mode you can set the Sample Rate and Record Length. Horizontal Scale is a dependent variable calculated from the sample rate and record length. Masks are not supported in manual mode.

The Horizontal Scale knob changes record length in manual mode.

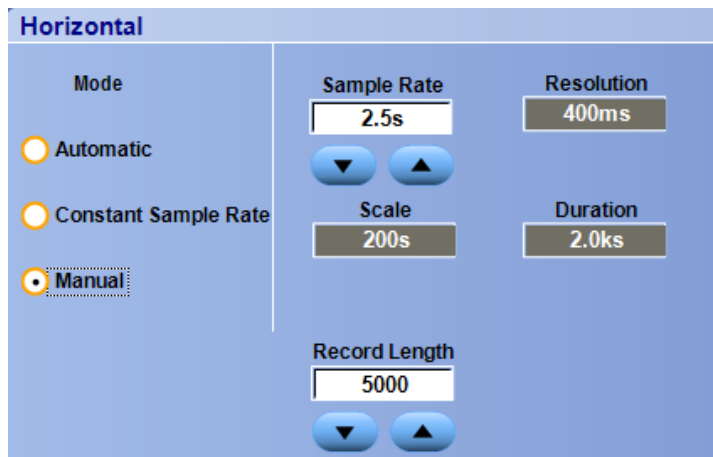

All three modes interact with sample rate, scale, and record length as shown. The horizontal line is the maximum real-time sample rate. Each staircase shows that as you increase the scale, the sample rate must decrease when either the maximum record length or the record length limit you set is reached. Manual mode uses the maximum record length.

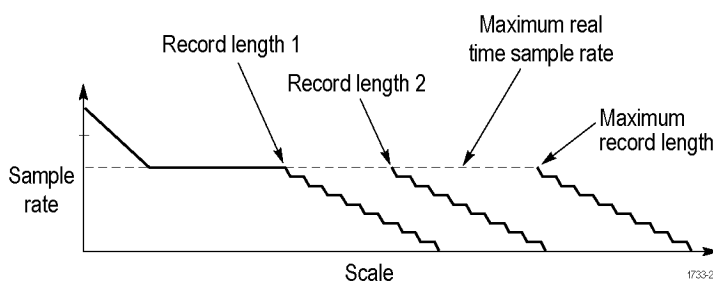

Automatic and Constant Sample Rate modes are identical. However, Constant Sample Rate mode keeps the sample rate constant at a rate that guarantees bandwidth enhancement filters are used.

Using FastAcq

Fast acquisition mode reduces the dead time between waveform acquisitions, enabling the capture and display of transient events such as glitches or runt pulses. Fast acquisition mode can also display waveform phenomena at an intensity that reflects their rate-of-occurrence.

Use the following procedure:

1. Press **FastAcq**.

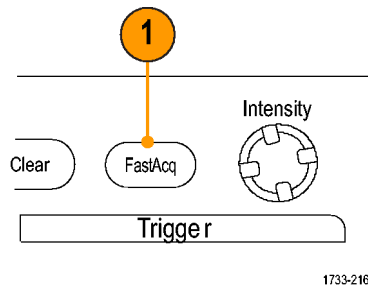

2. Find glitches, transients, or other random events.

When you have identified an anomaly, set the trigger system up to look for it. (See page 119, *Capturing Intermittent Anomalies*.)

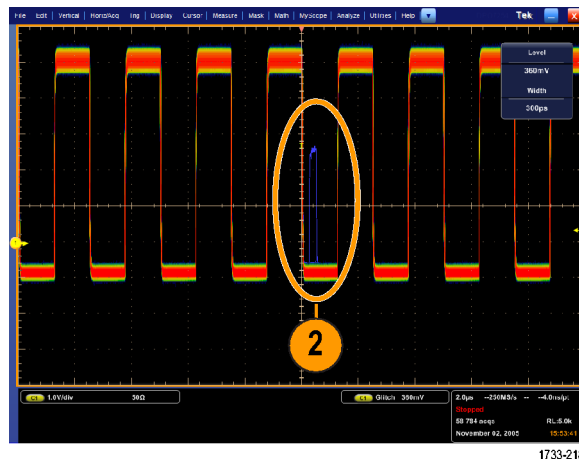

Quick Tips

- To optimize for capturing details or rare events, select **Horiz/Acq > Horizontal/Acquisition Setup > Acquisition > Fast Acq**, and then select Optimize For **Capturing Details** or **Capturing rare events**.

Using DSP Enhanced Bandwidth

If your instrument has the enhanced bandwidth feature, use the DSP (digital signal processing) enhanced bandwidth for more accurate rise time measurements, to extend the bandwidth, and flatten the passband at the full sample rate. The enhanced bandwidth provides a matched response across enabled channels so you can perform channel-to-channel comparison and differential measurements.

1. Push **AUTOSET** to set the horizontal, vertical, and trigger controls or set the controls manually.

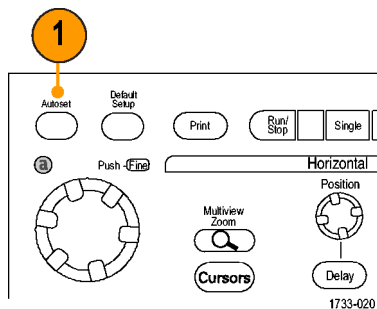

2. Select **Vertical > Bandwidth Enhanced...**

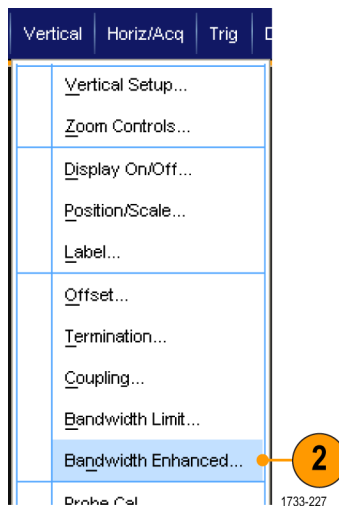

3. Click **Digital Filters (DSP) Enhanced** to turn the enhanced bandwidth on. You must set the sample rate correctly to enable DSP.
4. To force a constant sample rate that enables DSP filters, check **Force Constant Sample Rate**.

NOTE. If not already set, selecting *Constant Sample rate* sets the horizontal mode to constant sample rate, sets the sample rate to allow DSP, and selects a DSP bandwidth.

5. Select the desired bandwidth from the **Bandwidth** list.
The available bandwidth selections depend on your instrument, probe, probe tip.
Selecting *Analog Only* selects a hardware bandwidth.
6. To apply your selections to all channels, check **Apply To All Channels**.
When different probing makes it impossible for the instrument to set all channels the same, the instrument sets each channel to the closest bandwidth value possible.

The bandwidth indicator appears in the vertical readout when the enhanced bandwidth is turned on.

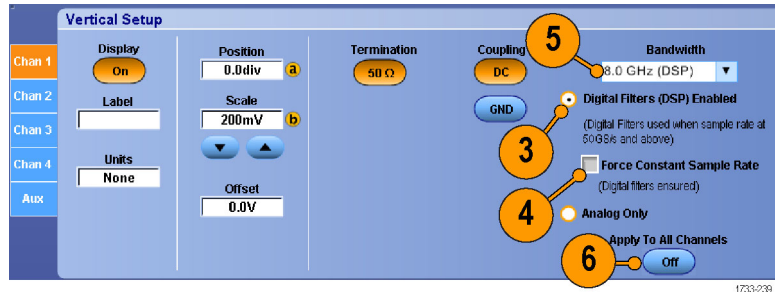

Quick Tips

- Right click on the waveform handle to display a menu where you can select the channel bandwidth and other bandwidth enhanced settings.
- The DSP enhanced bandwidth occurs at maximum sample rate.
- Use the DSP enhanced bandwidth when your signals have rise times less than 50 ps.
- Select *Analog Only* for higher waveform throughput, overdriven signals, and when you prefer to use your own DSP post-processing.
- You can limit the instrument bandwidth by selecting *Vertical > Bandwidth Limit* and then selecting the bandwidth.

Using Roll Mode

Roll mode gives a display similar to a strip chart recorder for low-frequency signals. Roll mode displays acquired data points without waiting for the acquisition of a complete waveform record.

1. Select **Horiz/Acq > Horizontal/Acquisition Setup...**

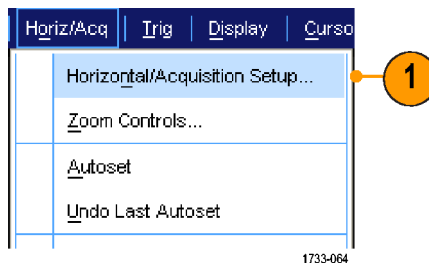

2. If not selected, click the **Acquisition** tab. Click **Auto** to turn on Roll mode.

NOTE. Roll mode requires Sample, Peak Detect, or Hi Res acquisition mode.

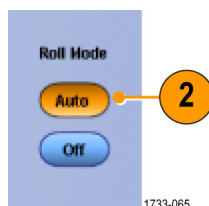

3. To stop acquisitions in Roll mode:

- If you are not in Single Sequence, push **RUN/STOP** to stop Roll mode.
- If you are in Single Sequence, Roll mode acquisitions stop automatically when a complete record is acquired.

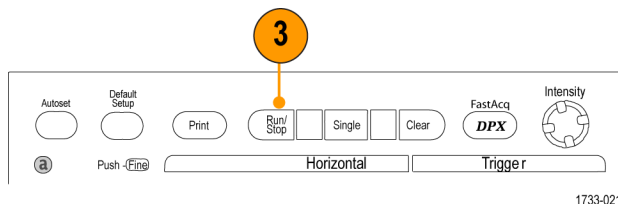

Quick Tips

- Switching to Envelope, Average, or WfmDB acquisition mode will turn off Roll mode.
- Roll mode is disabled when you set the horizontal scale to 50 ms per division or faster.

Using FastFrame Mode

FastFrame allows you to capture many trigger events as single records in a larger record, and then view and measure each record individually. Time Stamps display the absolute trigger time for a specific frame and the relative time between triggers of two specified frames.

1. Push **AUTOSET** to set the horizontal, vertical, and trigger controls or set the controls manually.

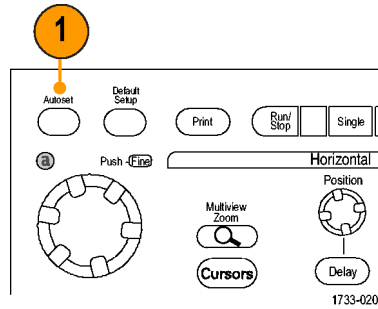

2. Select **Horiz/Acq > FastFrame Setup...**

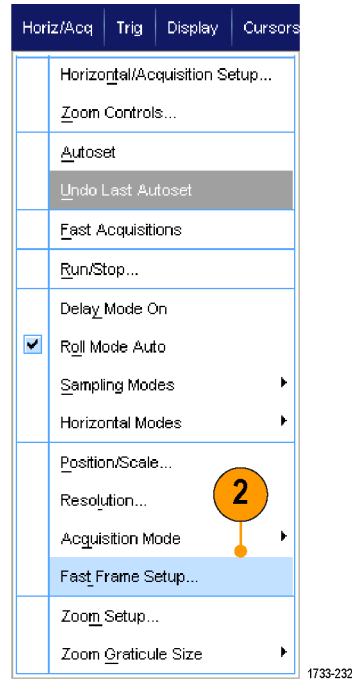

3. Push **FastFrame On**.
4. Select **Frame Size** and **# of Events Frames**. Then use the multipurpose knobs to set each one. Number of frames represents the number of trigger events that will be captured. Frame size is the number of samples that will be stored with each trigger event (or frame.) The number of frames will be reduced if there is insufficient memory to store all the records.

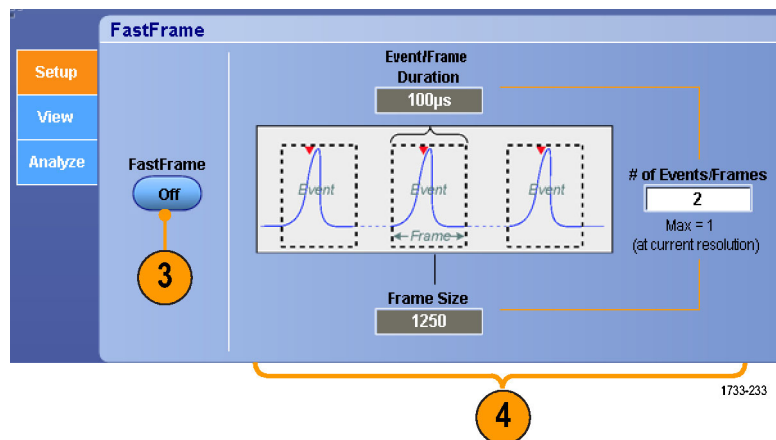

5. Use the Frame Viewing controls to select the frame that you want to view.
6. To view multiple frames superimposed over each other, select Overlay.

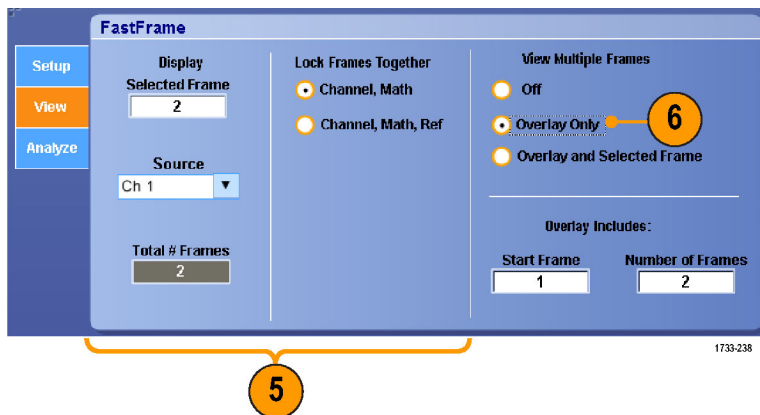

7. Use the Time Stamps controls to select the source for, and frame number of, the reference frame. The reference frame is the starting point when measuring the relative time between two frames.

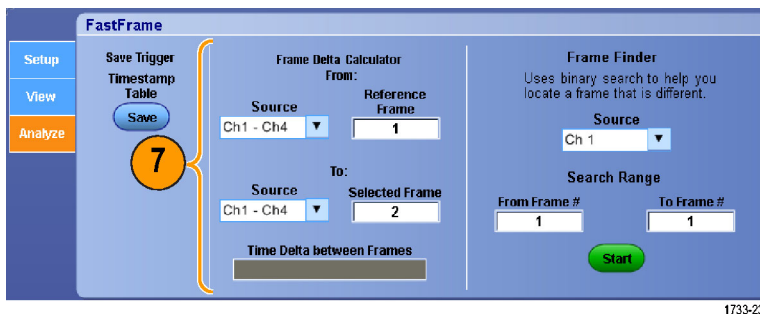

Quick Tips

- Use FastFrame when you want to preserve the data associated with each trigger event for further analysis or visual inspections.
- Use FastFrame when you want to capture multiple events that have long dead times between them that are of no interest to you.
- Multiple frames are best viewed with the Normal, Green, or Gray color palettes because the dark blue selected frame may be hard to distinguish if you use Temp or Spectral.

Using FastFrame Frame Finder

Frame finder allows you to find a FastFrame frame that is different from other frames.

1. Select the source of the FastFrame frames.
2. Set the Search Range by entering the **From Frame #** and the **To Frame #**.

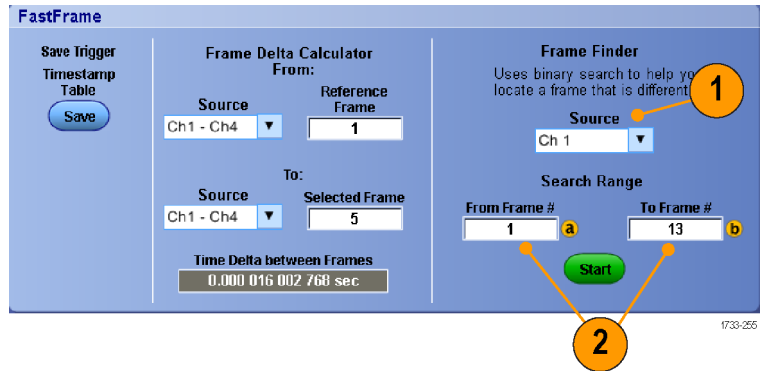

3. Push **Run/Stop** to stop acquisitions.

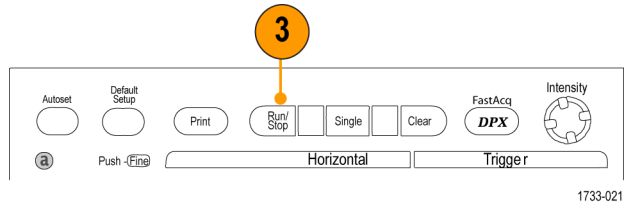

4. Push **Start** to start the search.

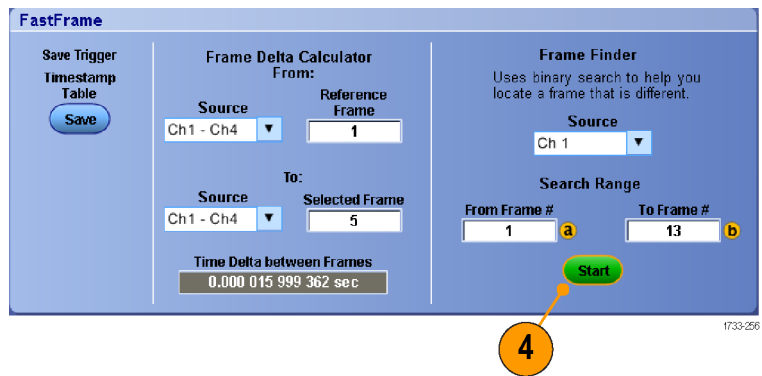

Frame Finder searches for and displays a different frame.

5. If the anomaly you are looking for is not in the displayed frame, push **No**. Frame Finder searches for another different frame.
6. If the anomaly you are looking for is in the displayed frame, push **Yes**.
7. If you are done searching, push **Stop**.
8. Push Run/Stop to restart acquisitions.

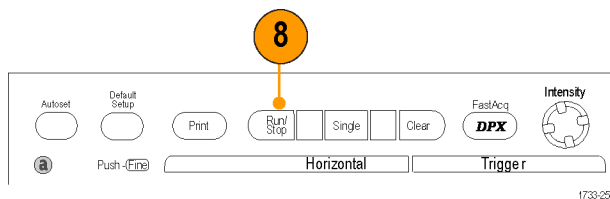
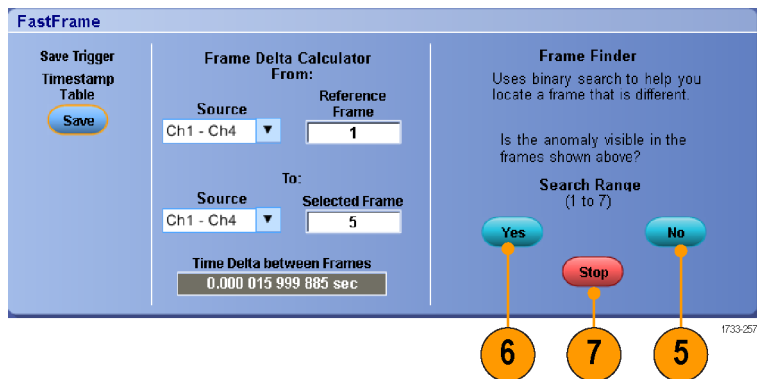

Pinpoint Triggers

The Pinpoint trigger system comes with advanced trigger types that are usable on both A and B triggers, and it can reset the trigger sequence if the B event does not occur after a specific number of events or a specific time. Pinpoint triggers support capture of events based on the most complex trigger event or sequence of trigger events.

This section contains concepts and procedures for using the trigger system.

Triggering Concepts

Trigger Event

The trigger event establishes the time-zero point in the waveform record. All waveform record data are located in time with respect to that point. The instrument continuously acquires and retains enough sample points to fill the pretrigger portion of the waveform record. When a trigger event occurs, the instrument starts acquiring samples to build the posttrigger portion of the waveform record (displayed after, or to the right of, the trigger event). Once a trigger is recognized, the instrument will not accept another trigger until the acquisition is complete and the holdoff time has expired.

Trigger Modes

The trigger mode determines how the instrument behaves in the absence of a trigger event:

- Normal trigger mode enables the instrument to acquire a waveform only when it is triggered. If no trigger occurs, the last waveform record acquired remains on the display. If no last waveform exists, no waveform is displayed.
- Auto trigger mode enables the instrument to acquire a waveform even if a trigger does not occur. Auto mode uses a timer that starts after a trigger event occurs. If another trigger event is not detected before the timer times out, the instrument forces a trigger. The length of time it waits for a trigger event depends on the time base setting.

Auto mode, when forcing triggers in the absence of valid triggering events, does not synchronize the waveform on the display. The waveform will appear to roll across the screen. If valid triggers occur, the display will become stable.

In edge-trigger mode, you can also force the instrument to trigger by pushing the Force Trigger button on the Trigger Setup control window.

Select the trigger mode in the Trig > Mode menu. For more information, see the instrument online help.

Trigger Holdoff

Trigger holdoff can help stabilize triggering, by extending the period in which further trigger recognition is suppressed after initiating an acquisition. Such an extension can help the system skip over the remaining events of a recurring burst of events, and thus always trigger on the first event in each burst. Adjust holdoff to obtain stable triggering when the instrument is triggering on undesired trigger events.

Set the trigger holdoff in the Trig > Holdoff menu. For more information, see the instrument online help.

Trigger Coupling

Trigger coupling determines what part of the signal is passed to the trigger circuit. Edge triggering can use all available coupling types: AC, DC, Low Frequency Rejection, High Frequency Rejection, and Noise Rejection. All other trigger types use DC coupling only.

Select the trigger coupling in the Trig > A Event (Main) Trigger Setup menu. For more information, see the instrument online help.

Horizontal Position

Horizontal position defines where the trigger occurs on the waveform record. It lets you choose how much the instrument acquires before and after the trigger event. The part of the record that occurs before the trigger is the pretrigger portion. The part that occurs after the trigger is the posttrigger portion.

Pretrigger data can be valuable when troubleshooting. For example, if you are trying to find the cause of an unwanted glitch in your test circuit, you can trigger on the glitch and make the pretrigger period large enough to capture data before the glitch. By analyzing what happens before the glitch, you may uncover information that helps you find the source of the glitch. Alternatively, if you want to see what is happening in your system as a result of the trigger event, make the posttrigger period large enough to capture data after the trigger.

Slope and Level

The slope control determines whether the instrument finds the trigger point on the rising or the falling edge of a signal. The level control determines where on that edge the trigger point occurs.

Delayed Trigger System

You can trigger with the A (Main) trigger system alone or you can combine the A (Main) trigger with the B (Delayed) trigger to trigger on sequential events. When using sequential triggering, the A trigger event arms the trigger system, and the B trigger event triggers the instrument when the B trigger conditions are met. A and B triggers can (and typically do) have separate sources. The B trigger condition can be based on a time delay or a specified number of events. (See page 47, *Using A (Main) and B (Delayed) Triggers.*)

Choosing a Trigger Type

Your instrument allows you to modify basic trigger parameters from the front panel or set up more advanced triggers in the Trigger Setup control window.

NOTE. Some trigger type selections are not available on some instruments.



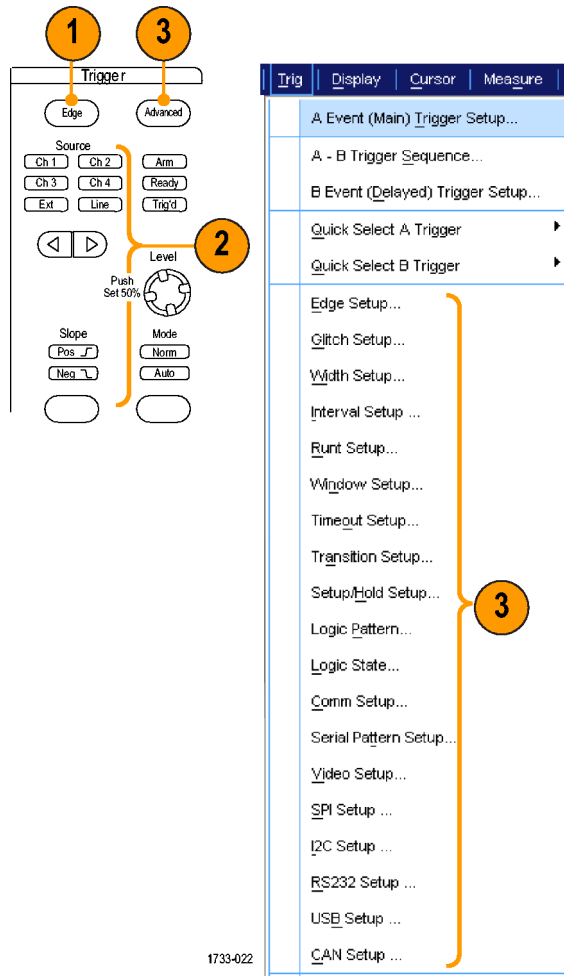



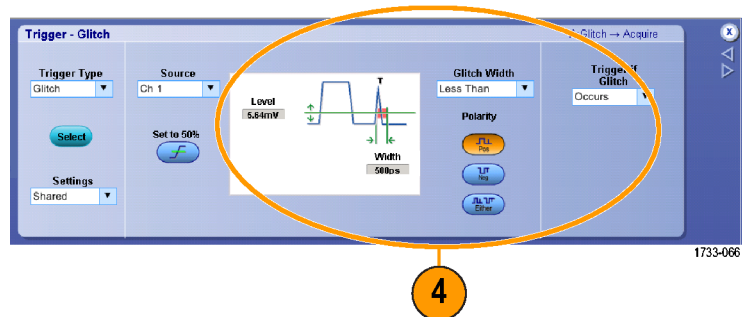







1. Push **EDGE**.
2. Set the source, slope and mode. To set the coupling use the Trig > Edge Setup menu.
3. To select one of the other trigger types, do one of the following:
 - Push **ADVANCED**
 - Select a trigger type directly from the Trig menu



4. Complete the trigger setup using the controls displayed for the trigger type. The controls to set up the trigger vary depending on the trigger type.



Pinpoint Trigger Selections

Trigger Type		Trigger Conditions
Edge		Trigger on a rising or falling edge, as defined by the slope control. Coupling choices are DC, AC, LF Reject, HF Reject, and Noise Reject.
Glitch		Trigger on a pulse narrower (or wider) than the specified width or ignore glitches narrower (or wider) than the specified width.
Width		Trigger on pulses that are inside or outside a specified time range. Can trigger on positive or negative pulses.
Runt		Trigger on a pulse amplitude that crosses one threshold but fails to cross a second threshold before recrossing the first. Can detect positive or negative runs, or only those wider than a specified width. These pulses can also be qualified by the logical state of other channels.
Window		Trigger when the input signal rises above an upper threshold level or falls below a lower threshold level. Trigger the instrument as the signal is entering or leaving the threshold window. Qualify the trigger event in terms of time by using the Trigger When Wider option, or by the logical state of other channels using the Trigger When Logic option.
Timeout		Trigger when no pulse is detected within a specified time.
Transition		Trigger on pulse edges that traverse between two thresholds at faster or slower rates than the specified time. The pulse edges can be positive or negative.
Serial		<p>Trigger on 64-bit serial pattern at data rates up to 1.25 Gb/s (<4 GHz models) and 40-bit serial patterns up to 3.125 Gb/s (≥4 GHz models only). Lock on a pseudo-random bit sequence. Requires Option PTM or PTH. This mode includes clock recovery. Push the Push Set 50% knob to reinitialize clock recovery.</p> <p>Pattern Lock automatically finds and locks on a long repeating pseudo-random bit sequence (PRBS). This lock means that the instrument knows the bit length of the pseudo-random bit sequence and can predict when the cycle repeats. Pattern Lock enables the instrument to take samples at specific locations in a data pattern with outstanding timebase accuracy.</p>
Pattern		Trigger when logic inputs cause the selected function to become True or False. You can also specify that the logic conditions must be satisfied for a specific amount of time before triggering.
State		Trigger when all of the logic inputs to the selected logic function cause the function to be True or False when the clock input changes state.
Setup/ Hold		Trigger when a logic input changes state inside of the setup and hold times relative to the clock. The mode triggers on a setup and hold violation.
Comm		Trigger in conjunction with mask testing on communications codes and standards. The controls work together to define the parameters for the trigger event (available with Option MTM or MTH). This mode includes clock recovery. Push the Push Set 50% knob to reinitialize clock recovery.
Video		Trigger on specified fields or lines of a composite video signal. Only composite signal formats are supported.
SPI		Trigger on Serial Peripheral Interface (SPI) signals.

Trigger Type

Trigger Conditions

I²C

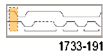

Trigger on Inter-IC Control (I²C) signals: start, stop, repeated start, missing acknowledge, address, data, and address and data.

RS-232

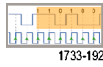

Trigger on RS-232 signals.

CAN



Trigger on CAN Bus signals.

Checking Trigger Status

You can check the trigger status from the status lights on the front panel or from the readout.

Check the ARM, READY, and TRIG'D front-panel controls to determine the trigger status.

- If TRIG'D is on, the instrument has recognized a valid trigger and is filling the posttrigger portion of the waveform.
- If READY is on, the instrument can accept, and is waiting for, a valid trigger to occur. Pretrigger data has been acquired.
- If ARM is on, the trigger circuitry is filling the pretrigger portion of the waveform record.
- If both TRIG'D and READY are on, a valid A event trigger has been recognized and the instrument is waiting for a delayed trigger. When a delayed trigger is recognized, the posttrigger portion of the delayed waveform will fill.
- If ARM, TRIG'D, and READY are off, acquisitions have stopped.

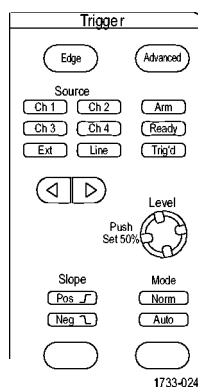

To quickly determine the settings of some key trigger parameters, check the Trigger readout at the bottom of the display. The readouts differ for edge and the advanced triggers:

1. A trigger source = Ch1
2. Trigger slope = rising edge
3. Trigger level
4. Time base

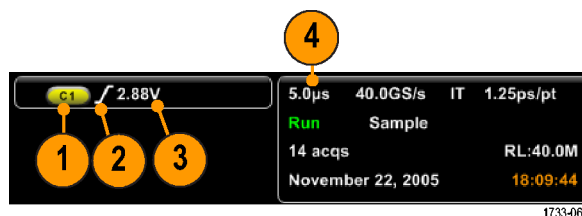

Using A (Main) and B (Delayed) Triggers

You can use the A Event (Main) trigger for simple signals or combine it with the B Event (Delayed) trigger to capture more complex signals. After the A Event occurs, the trigger system looks for the B Event before triggering and displaying the waveform.

A Trigger

1. Select Trig > A Event (Main) Trigger Setup....



2. Set the A trigger type and source in the A Event tab.

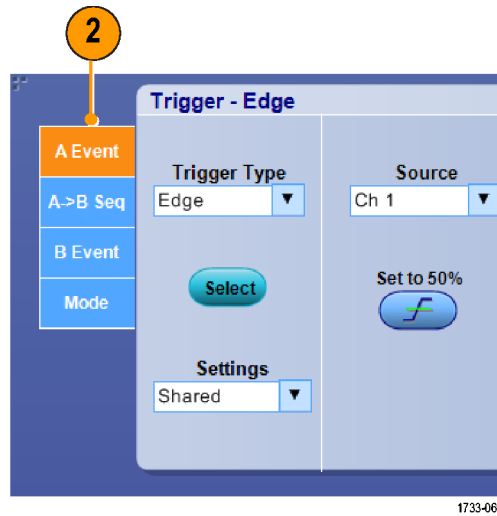

B Trigger (Delayed)

3. Choose a function in the A →B Seq tab.
4. Set the trigger delay time or the number of B events.

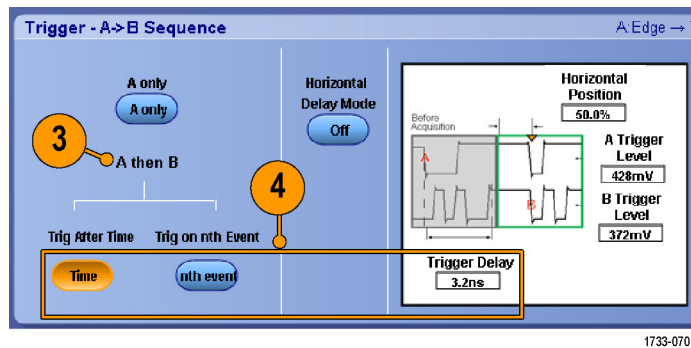

- Set the B trigger characteristics in the B Event (Delayed) tab.

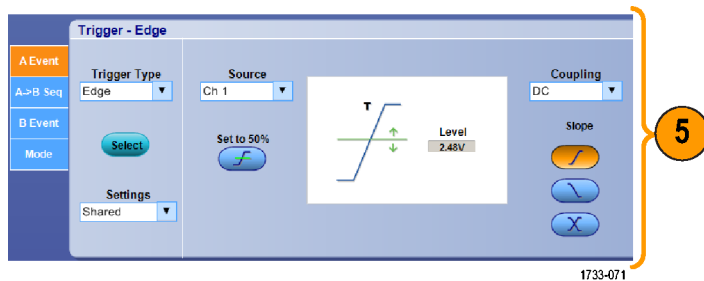

- Select **Normal** Trigger Mode and **Auto** Holdoff in the Mode tab.

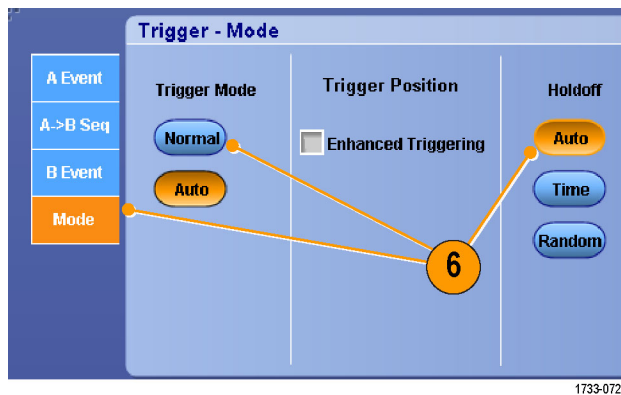

Trigger on B Event

The A trigger arms the instrument. Posttrigger acquisition starts on the nth B event.

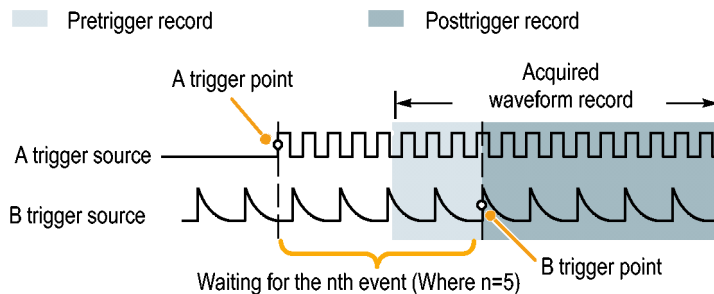

B Trigger After Delay Time

The A trigger arms the instrument. Posttrigger acquisition starts on the first B edge after the trigger delay time.

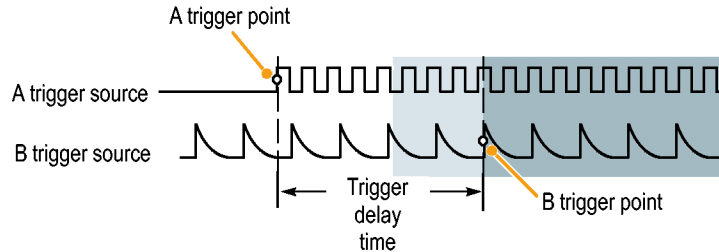

Triggering with Reset

You can specify a condition to reset the trigger system if it occurs before the B trigger event. When the reset event occurs, the trigger system stops waiting for the B event and returns to waiting for the A event.

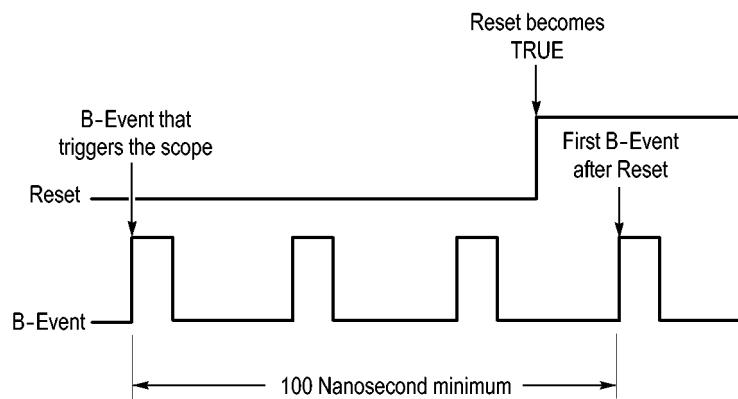

Quick Tips

- B-trigger delay time and horizontal delay time are independent functions. When you establish a trigger condition using either the A trigger alone or the A and B triggers together, you can also use horizontal delay to delay the acquisition by an additional amount.

Correcting Trigger Position

Trigger position correction corrects for differences in the data path and the trigger path to more accurately place the trigger on the displayed waveform. Trigger position correction can also use averaging to more accurately place the trigger on noisy signals. To more accurately place edge triggers on the display, perform the following procedure.

- To more accurately place the trigger on the display, check **Enhanced Triggering**. To more accurately place the trigger on noisy signals, also check **Optimized for Noisy Signals**. The **Optimized for Noisy Signals** selection is only available if **Enhanced Triggering** is selected.

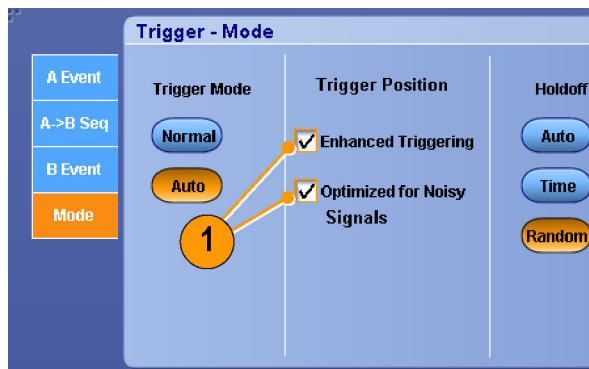

1733-259

Sending E-mail on Trigger

You must configure e-mail on event before performing the following procedure. (See page 128, *Setting Up E-mail on Event*.)

- Select **Trig > A Event (Main) Trigger Setup...**
- Select the **Mode** tab.
- Under E-mail on Trigger, click **On**, and then click **Setup**. (See page 128, *Setting Up E-mail on Event*.)

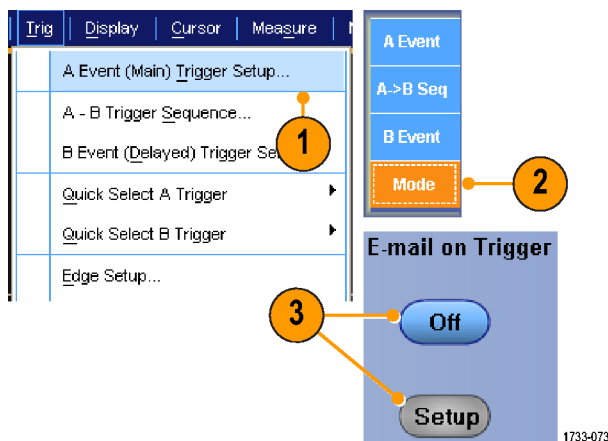

1733-073

Using Horizontal Delay

Use horizontal delay to acquire waveform detail in a region that is separated from the trigger location by a significant interval of time.

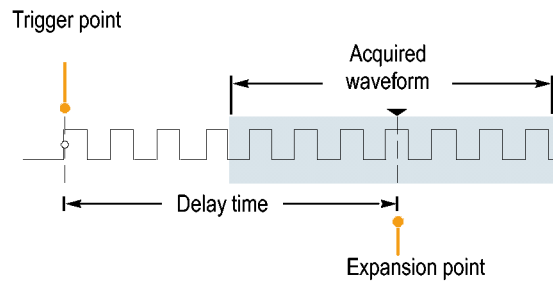

1. Push **DELAY**.
2. Adjust the delay time with the horizontal **POSITION** control, or enter the delay time in the control window.
3. Adjust the horizontal **SCALE** to acquire the detail that you need.

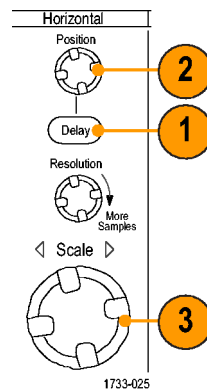

Quick Tips

- Use MultiView Zoom and Horizontal Delay together to magnify a delayed acquisition.
- Toggle Horizontal Delay on and off to quickly compare signal details at two different areas of interest, one near the trigger location and the other centered at the delay time.

Display a Waveform

This section contains concepts and procedures for displaying a waveform. Detailed information is available in the online help.

Setting the Display Style

To set the display style select **Display > Display Style**, and then select one of the following styles:



Displays waveforms with lines drawn between record points.



1733-075

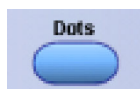

Displays waveform record points as dots on the screen.



1733-076



Displays the actual samples. Interpolated points are not displayed.



1733-077

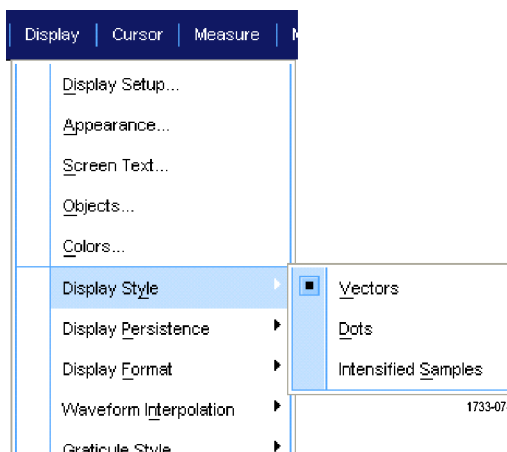

Setting the Display Persistence

Select **Display > Display Persistence**, and then select the type of persistence.

- No persistence shows record points for the current acquisition only. Each new waveform record replaces the previously acquired record for a channel.
- Infinite persistence continuously accumulates record points until you change one of the acquisition display settings. Use for displaying points that may occur outside the normal acquisition envelope.
- Variable persistence accumulates record points for a specified time interval. Each record point decays independently according to the time interval.
- Reset persistence clears the persistence.

1. To set the variable persistence time, select **Display > Display Persistence > Persistence Controls...**
2. Click **Variable, Persist Time**, and then use the multipurpose knobs to set the persistence time.

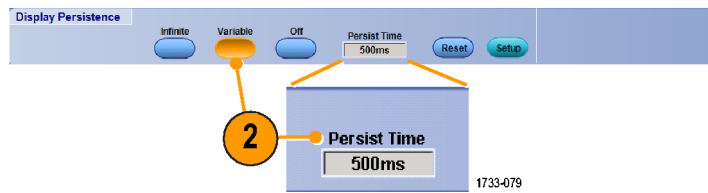
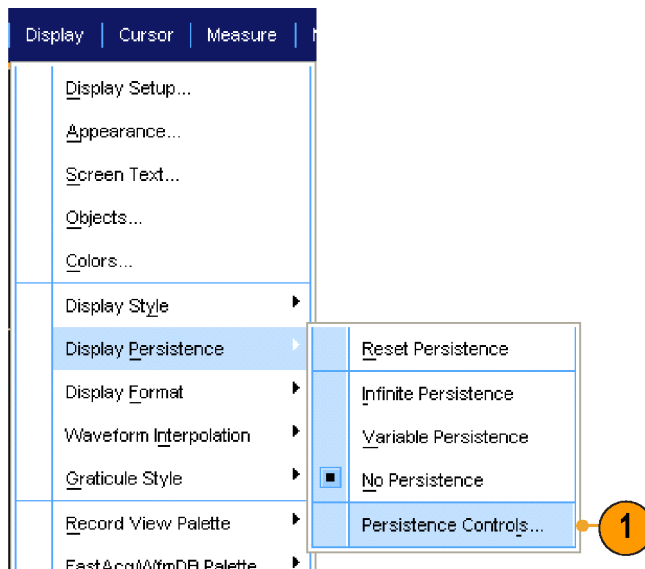
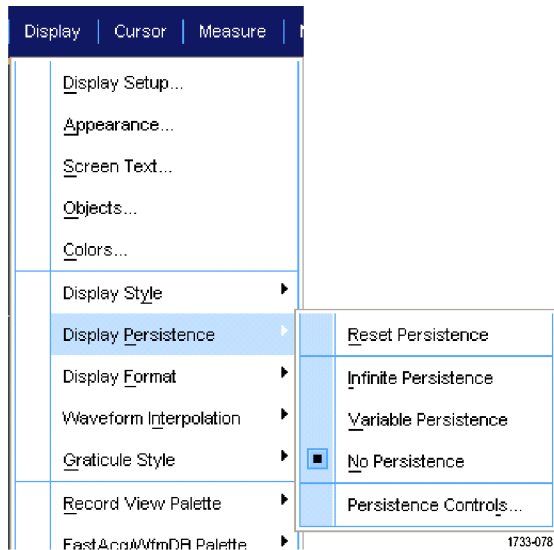

Setting the Display Format

The instrument can display waveforms in two different formats. Choose the format that best suits your needs.

Select **Display > Display Format**.

- Select **Y-T** format to show a signal amplitude as it varies over time.
- Select **X-Y** format to compare the amplitude of waveform records point by point:

For instruments <4 GHz the following channels are compared: Ch 1 (X) and Ch 2 (Y), Ch 3 (X) and Ch 4 (Y), Ref 1 (X) and Ref 2 (Y), or Ref 3 (X) and Ref 4 (Y)

For instruments \geq 4 GHz the following channels are compared: Ch 1 (X) and Ch 3 (Y), Ch 2 (X) and Ch 4 (Y), Ref 1 (X) and Ref 2 (Y), or Ref 3 (X) and Ref 4 (Y)

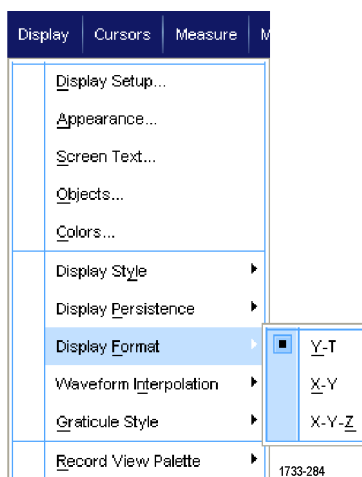

- Select **X-Y-Z** format to compare the voltage levels of the Ch 1 (X) and Ch 2 (Y) waveform records point by point as in XY format. The displayed waveform intensity is modulated by the Ch 3 (Z) waveform record. XYZ format is triggered. A -5 division signal (including position and offset) on Ch 3 produces a blank screen; a +5 division signal produces full intensity.

Quick Tips

- XY format is particularly useful for studying phase relationships such as Lissajous Patterns.
- XY format is a dot-only display, although it can have persistence. The Vector style selection has no effect when you select XY format.

Selecting the Waveform Interpolation

Select **Display > Waveform Interpolation**, and then select one of the following:

- Sin(x)/x interpolation computes record points using a curve fit between the actual samples acquired.
- Linear interpolation computes record points between actual acquired samples by using a straight line fit.

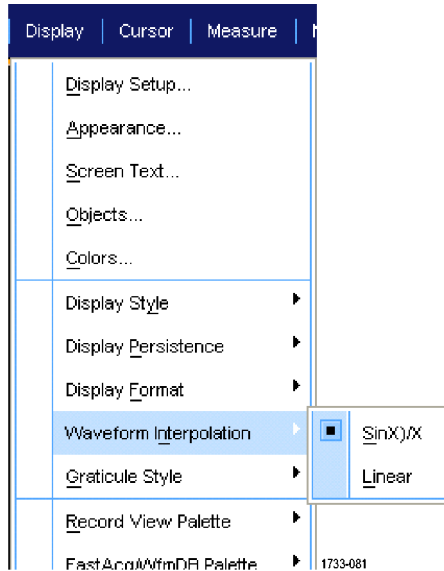

Quick Tips

- Sin(x)/x interpolation is the default interpolation mode. It requires fewer actual sample points than linear interpolation to accurately represent the waveform.

Adding Screen Text

1. Select **Display > Screen Text**.

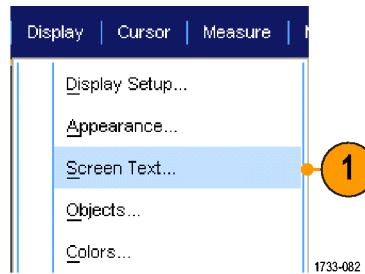

2. Enter up to eight independent lines of text.
3. Click **Text Off** or **On** to turn the text display on and off.
4. Click **Font** or **Color** to select the font and color of the screen text.
5. Click **Controls** to open the Text Properties control window for positioning of the text on the display.
6. Click **Clear** to erase the entire text of the selected line.

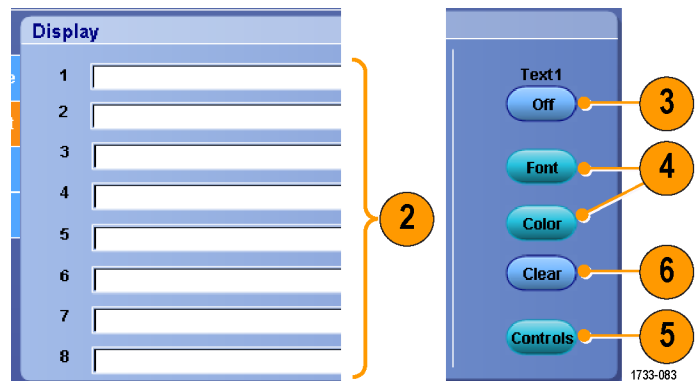

Quick Tips

- You can click and drag screen text to reposition it on the screen.

Setting the Graticule Style

To set the graticule style, select **Display > Graticule Style**, and then select one of the following styles:

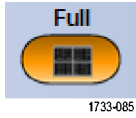

Use for quick estimate of waveform parameters.

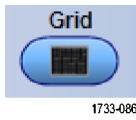

Use for full-screen measurements with cursors and automatic readouts when cross-hairs are not needed.

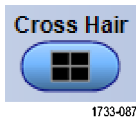

Use for making quick estimates of waveforms while leaving more room for automatic readouts and other data.



Use with automatic readouts and other screen text when display features are not needed.

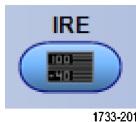

Use for NTSC video signals.

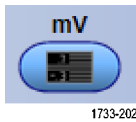

Use for video signals other than NTSC.

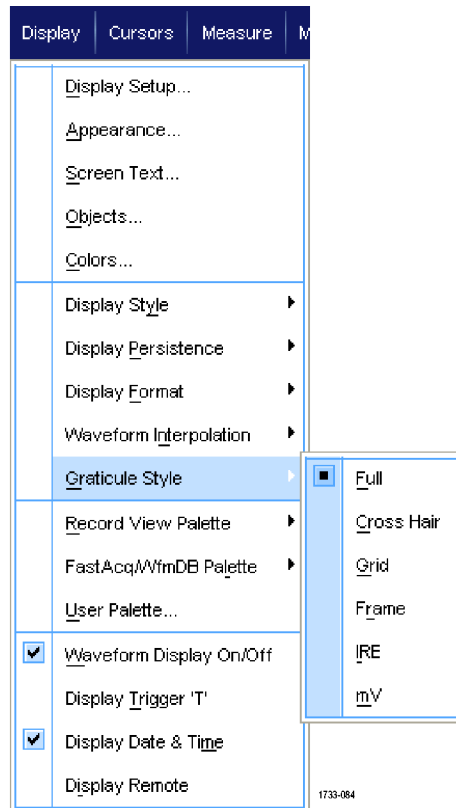

Setting the Trigger Level Marker

1. Select **Display > Objects...**
2. Select one of the following:
 - **Short** displays a short arrow on the side of the graticule.
 - **Long** displays a horizontal line across the graticule.
 - **Off** turns off the trigger level marker.

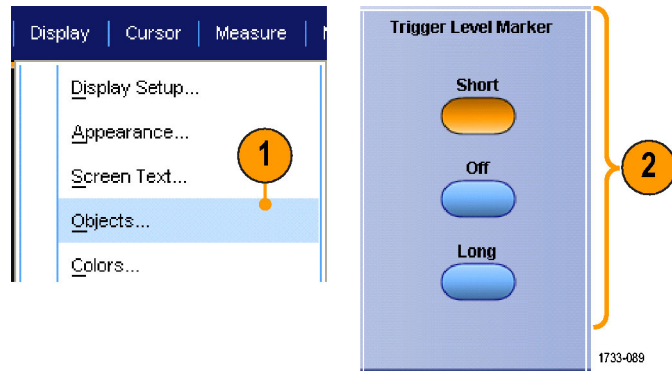

Displaying the Date and Time

1. Select **Display > Objects...**
2. Toggle the display of the date and time on the graticule. Use the Utilities menu to set the date and time.

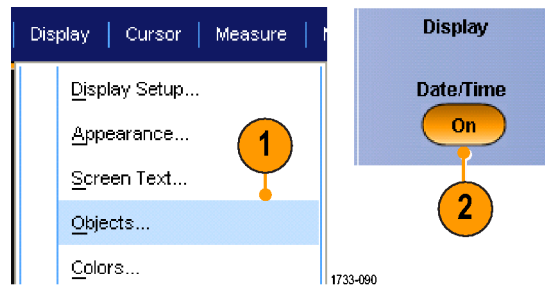

Using the Color Palettes

Select **Display > Record View Palette** or **FastAcq/WfmDB Palette**, and then select one of the following color schemes for the waveform and graticule:

- Normal displays hues and lightness levels for best overall viewing. The color of each channel waveform matches the color of the corresponding front-panel vertical knob.
- Temperature Grading displays areas of the waveform with the highest sample density in red shades. The areas of lowest sample density appear in blue shades.
- Monochrome Green displays areas of the waveform with the highest sample density in lighter green shades. The areas of lowest sample density appear in darker green shades. It most closely resembles analog oscilloscope displays.

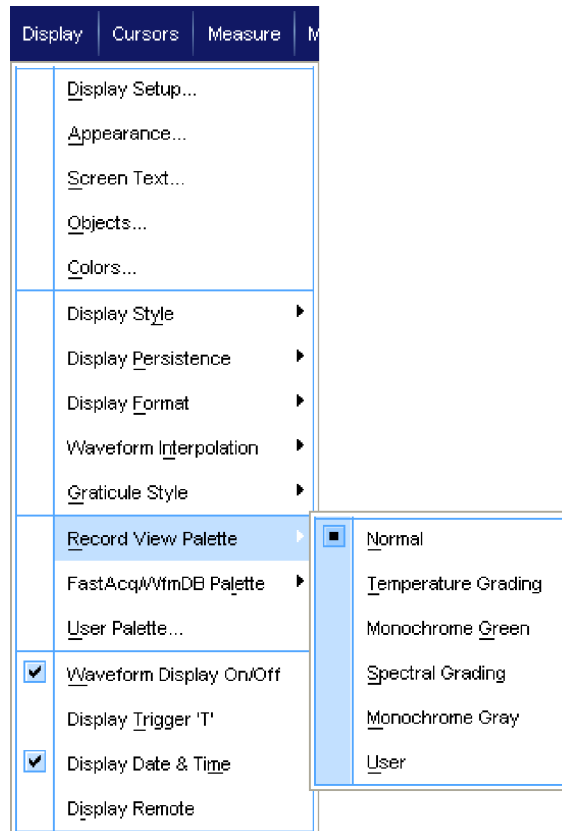

- Spectral Grading displays areas of the waveform with the highest sample density in blue shades. The areas of lowest sample density appear in red shades.
- Monochrome Gray displays areas of the waveform with the highest sample density in lighter gray shades. The areas of lowest sample density appear in darker gray shades.
- User displays the waveform in a user-defined color.

Quick Tips

- Choose one of the color grading palettes in the **Display > Colors** control window to see different sample densities represented in different colors.
- There are two color palettes, one for Record View and one for FastAcq/WfmDB.

Setting the Reference Colors

Select **Display > Colors...**, and then select one of the following:

- Default uses the default system color for reference waveforms.
- Inherit uses the same color for the reference waveform as the original waveform.

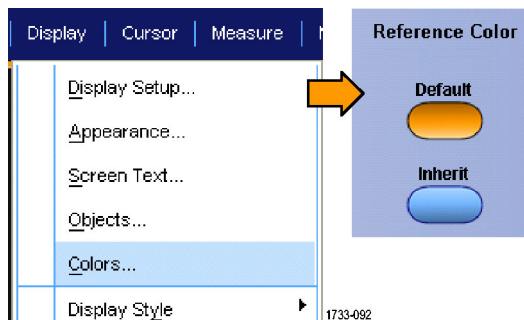

Setting Math Colors

Select **Display > Colors...**, and then select one of the following:

- Default uses the default system color for math waveforms.
- Inherit uses the same color for the math waveform as the lowest numbered channel waveform the math function is based on.

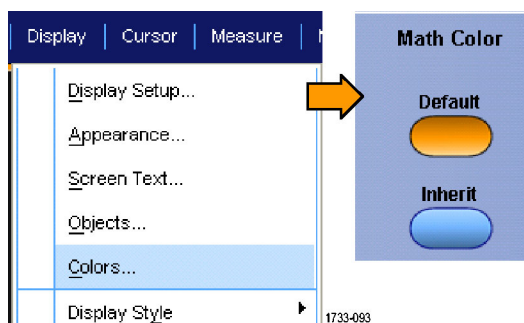

Quick Tips

- The default color for math and reference waveforms are different for each waveform.

Using MultiView Zoom

Use the MultiView Zoom function to magnify a waveform vertically, horizontally, or in both dimensions. Zoomed waveforms can also be aligned, locked, and automatically scrolled. Scale and Position affect only the display, not the actual waveform data.

1. Push **MultiView Zoom** to split the screen and add a zoom graticule.

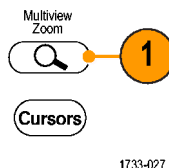

2. Push **HORIZ** or **VERT** to select which axis to magnify in the zoom graticule. Use the multipurpose knobs to adjust scale and position of the magnified waveform.

In this example the main graticule is the top half of the graticule and the zoomed graticule is the bottom half of the graticule.

NOTE. You can hide or display zoomed waveforms by pressing Waveforms **Hide** and then checking which zoomed waveforms to display.

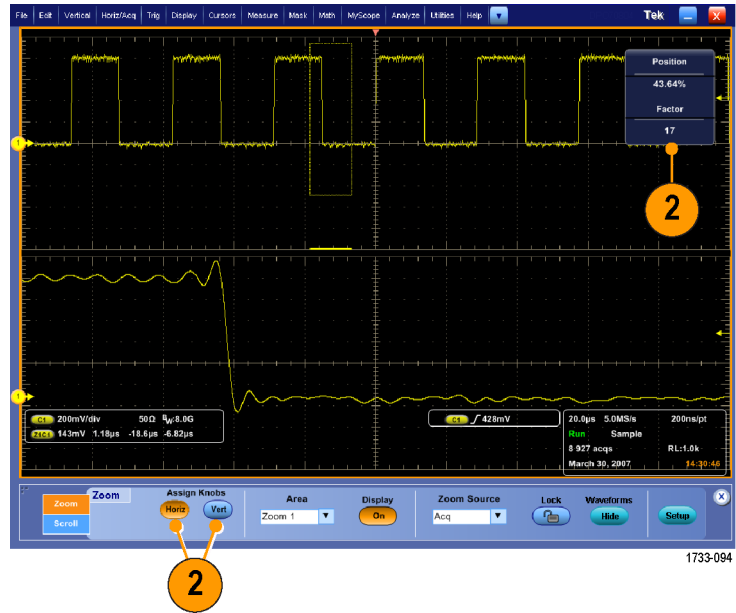

3. To adjust the zoom graticule size, select Zoom Graticule Size from either the Vertical or Horiz/Acq menus.
4. To turn zoom off, push the front-panel button.

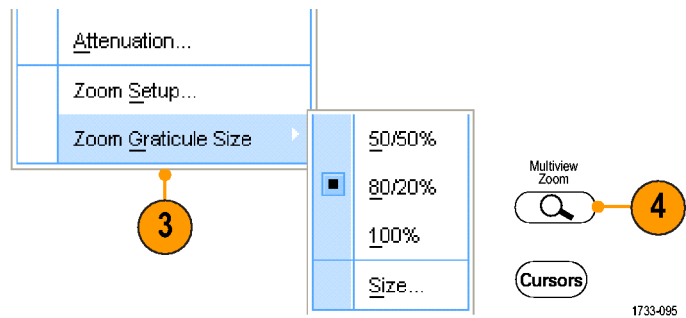

Quick Tips

- You can also use the Zoom Setup menu to change the graticule size of the zoomed waveform.

Zooming in Multiple Areas

When you want to view and compare multiple areas of one record at the same time, use the following procedure.

1. Click and drag a box around the area of the waveform that you want to zoom.
2. Select **Zoom 1 On**.

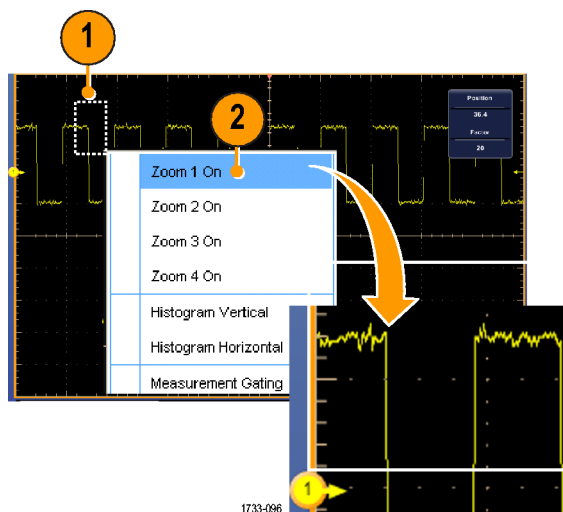

3. Click and drag a box around another area of the waveform that you want to zoom, and then select **Zoom 2 On**.

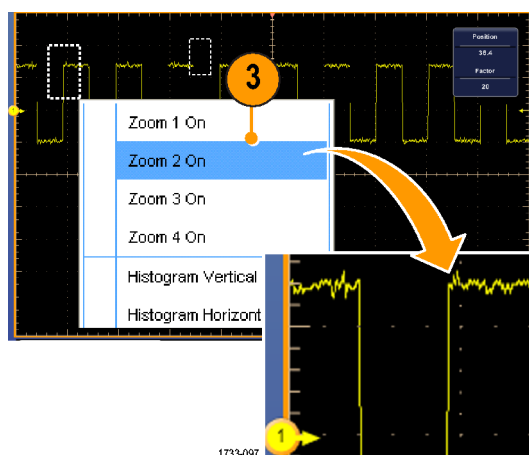

4. To adjust the zoomed area horizontally, click the horizontal marker below the Zoom box to select the zoomed area.
5. Use the multipurpose knobs to adjust the horizontal position and factor of the selected zoom area.

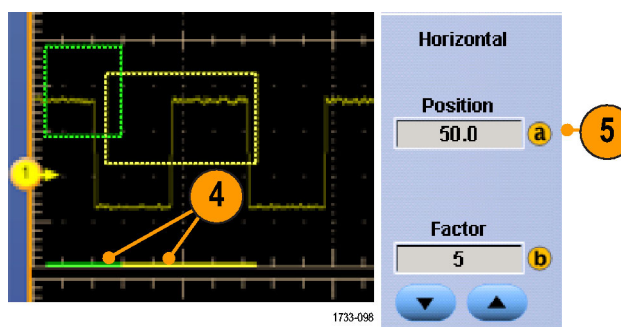

6. To adjust the zoomed area vertically, select **Vertical > Zoom Setup...**, click a vertical field, and then use the multipurpose knobs to adjust the Vertical Position and Factor.

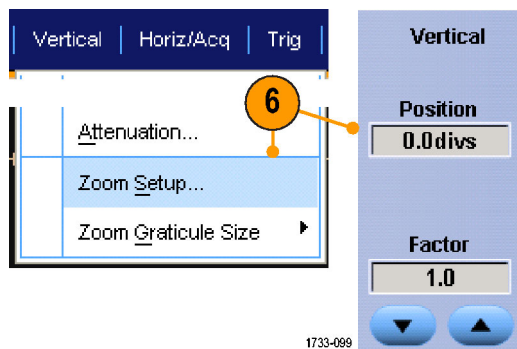

Quick Tips

- To clear the zoom area, click **Position Factor Reset** from the Zoom Setup control window.
- You can turn each zoom display on and off from the Zoom Setup control window.
- Push the **MultiView Zoom** button to toggle all zoom displays on and off.
- To reposition the zoomed area horizontally, click and drag the horizontal marker at the bottom of the zoom box.

Lock and Scroll Zoomed Waveforms

1. To use Lock and Scroll select **Zoom Setup...** from either the Vertical or Horiz/Acq menu, and then select the **Lock and Scroll** tab.

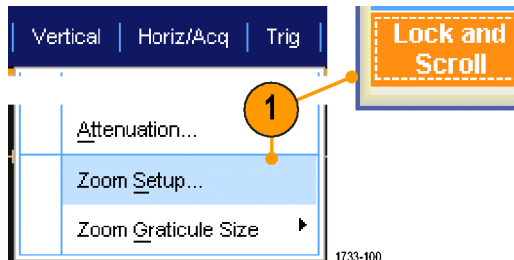

2. To scroll a single zoomed area, select a **Zoom 1-4** check box, and then click an Auto Scroll button.

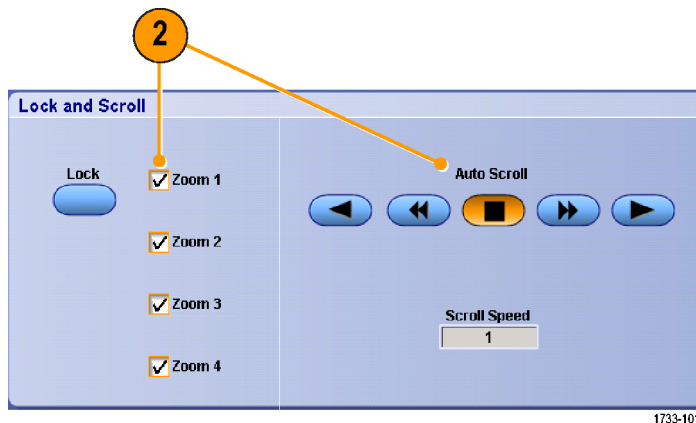

3. To scroll multiple zoomed areas simultaneously, click **Lock**, and then select the **Zoom 1-4** check boxes that you want to scroll through.
Locking the zoomed areas locks in their relative horizontal position. Changing the horizontal position of one locked and zoomed area changes them all.

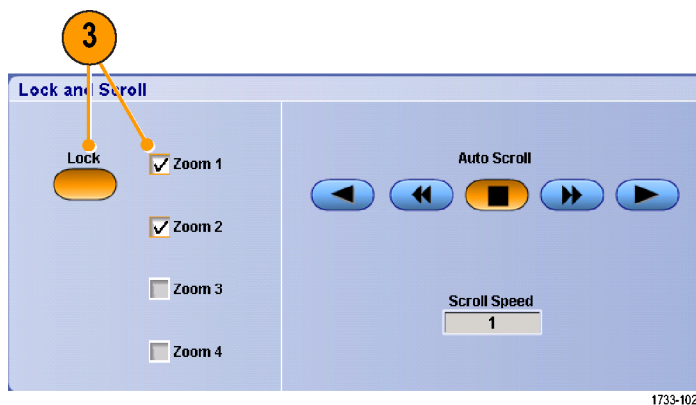

Quick Tips

- When multiple zoom areas are selected but not locked, the zoom area with the highest number will autoscroll, while the other zoom areas remain stationary.

Hide Waveforms in the Zoomed Window

1. To hide or view waveforms, select **Zoom Setup...** from either the Vertical or Horiz/Acq menu, press **Controls**, and then press **Waveforms Hide**.

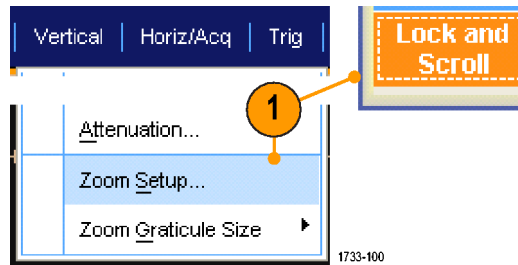

2. Select the zoomed area that contains the waveform you want show or hide.
3. Uncheck the channel, math, or reference waveform you want to hide.

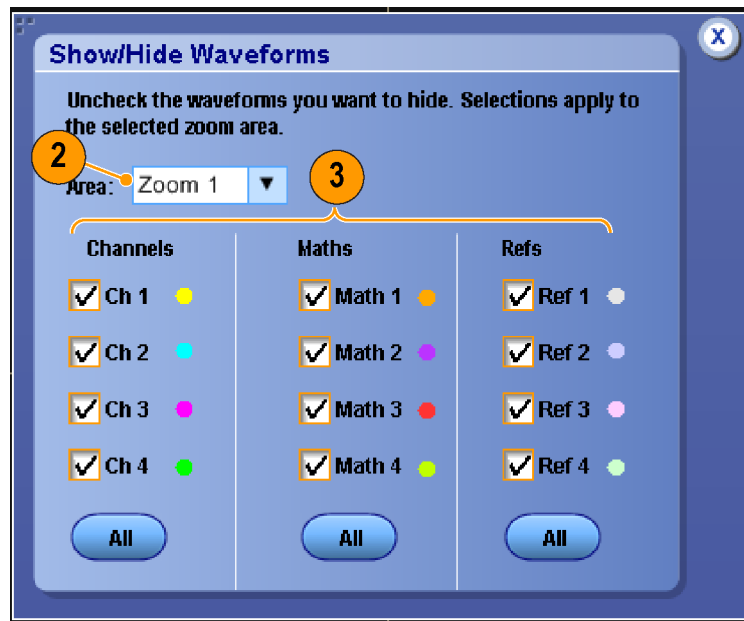

Searching and Marking Waveforms

You can mark locations of interest in the acquired waveform. These marks help you limit your analysis to particular regions of the waveform. You can mark areas of the waveform automatically, if they meet some special criteria, or you can manually mark each item of interest. You can jump from mark to mark (area of interest to area of interest). With the Advanced Search and Mark option, you can automatically search and mark many of the same parameters that you can trigger on. Many search parameters don't have the time limits as triggers. You can search on math and reference waveforms. You can find all of the acquired events of a certain type.

Search marks provide a way to mark a waveform region for reference. You can set marks automatically with search criteria. You can search for and mark regions with particular edges, pulse widths, runts, logic states, rise/fall times, setup and hold violations, and bus search types.

To Manually Set and Clear (delete) Marks:

1. Press **Multiview Zoom**. Zoom 1 is used with marks.

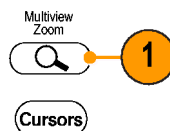

1733-027

2. Select **Analyze > Search**.

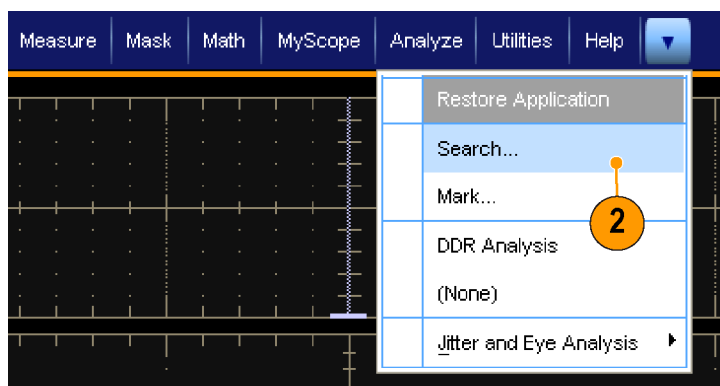

1733-305

3. Move (the zoom box) to the area on the waveform where you want to set (or clear) a search mark by turning a multipurpose knob.
Push the **Next** or **Prev** button to jump to an existing mark.

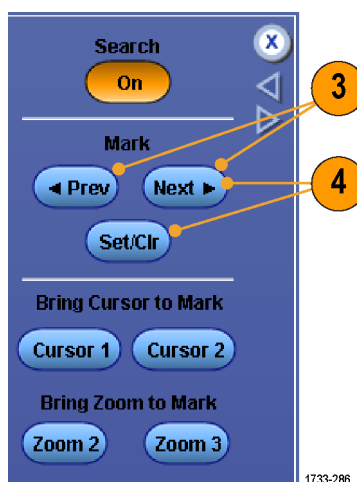

1733-286

4. Push **Set Clr**.
If no search mark is at the screen center, the instrument will add one.
When a mark is created, the horizontal zoom factor is saved. When you use Next or Prev to move between marks, the zoom factor is restored.

- Investigate your waveform by moving from search mark to search mark. Use the **Next** or **Prev** button to jump from one marked location to another, without adjusting any other controls.
- Delete a mark. Push the **Next** or **Prev** button to jump to the mark you want to clear. To remove the center-positioned mark, push **Set Clr**. It works on both manually and automatically created marks.

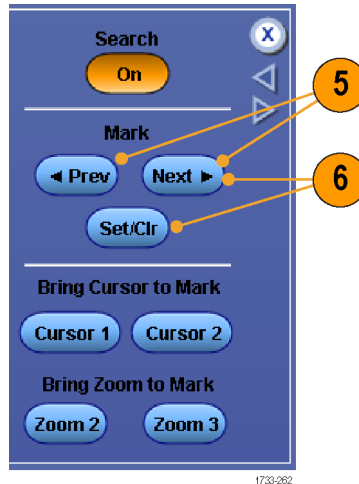

To Automatically Set and Clear (delete) Search Marks:

- Select **Analyze > Search**.

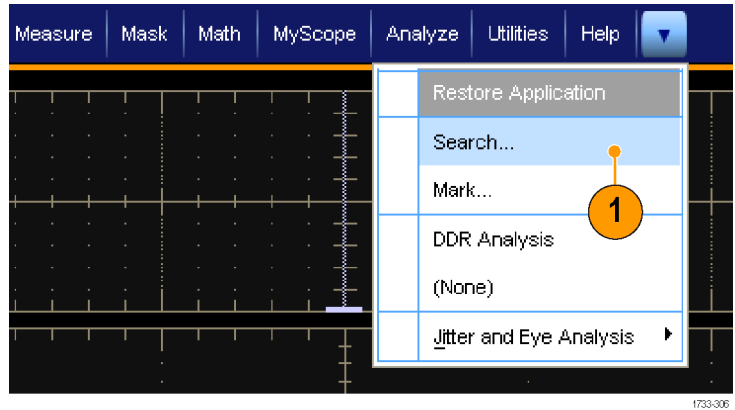

- Select the desired search type from the menu.
The search menu is similar to the trigger menu.
Edge type is standard; other search types are optional.

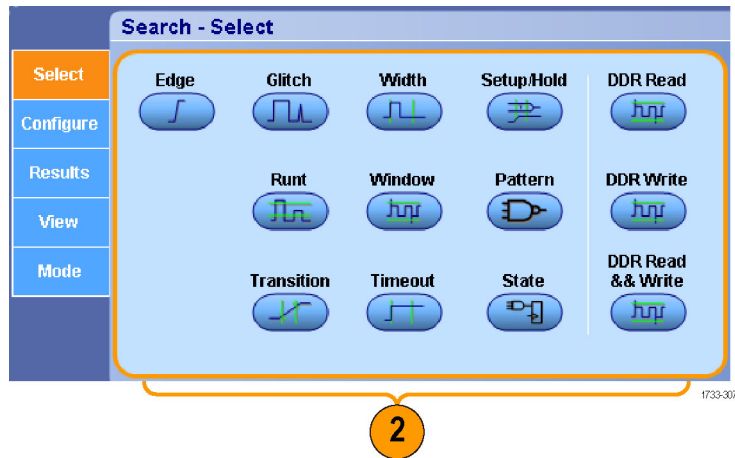

3. Set up your search from the Configure tab. To copy the trigger setup or a search setup, press Settings Copy.
4. From the Copy Settings window, select where to copy the settings from and where to copy the settings to. Press Copy and then Close.

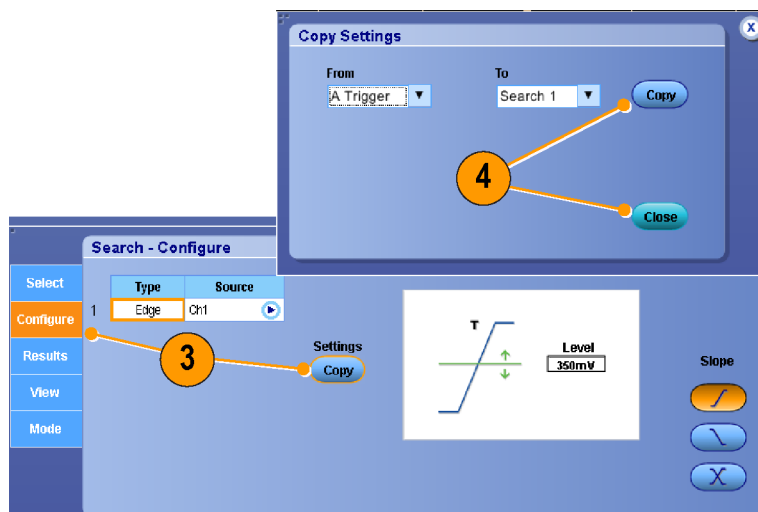

1733-265

5. To modify the current search setup, adjust the displayed controls. Displayed controls vary depending on the selected search.

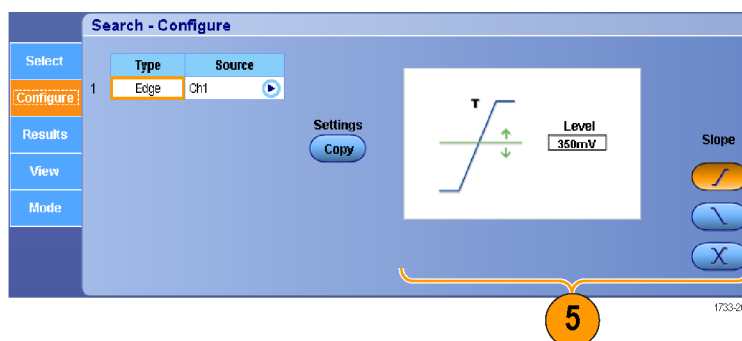

1733-266

6. If not already on, press Search to toggle search to on.

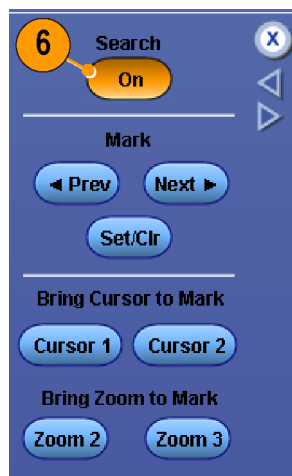

1733-267

- On the screen, green triangles show the location of automatic marks and white triangles show the custom (user-defined) locations. These appear on both normal and zoomed waveform views.

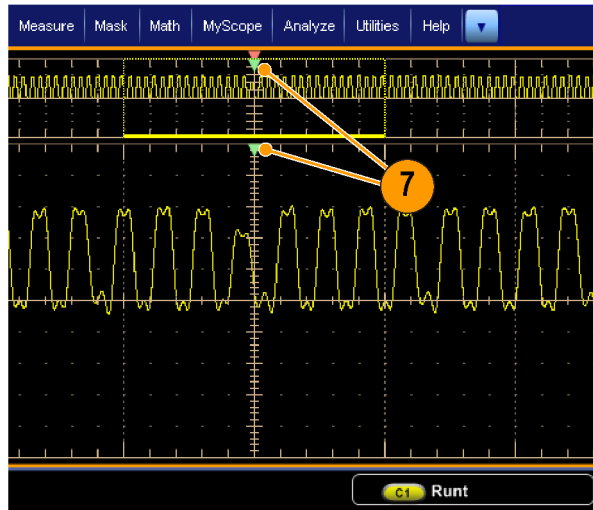

1733-268

- You can quickly investigate your waveform by moving from mark to mark with the **Next** and **Prev** arrow buttons. No other adjustments are needed.

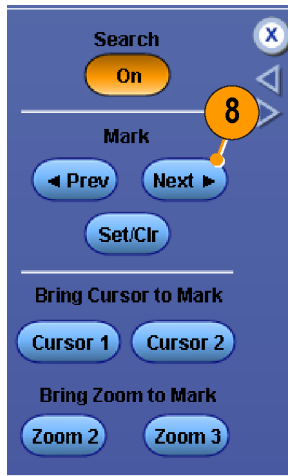

1733-269

- To toggle between the display of search events counts or Marks time, select the **Results** tab and press **View Count**.
- To clear all marks from the table, press **All Marks Clear**.
- To export the Mark Table to a file, press **All Marks Export**.

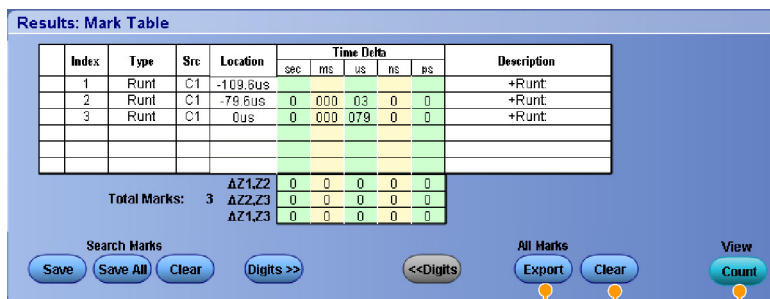

1733-270

12. To convert a mark or all marks to user marks, press Search Marks **Save** or **Save All**.
13. To remove the currently highlighted row from the Mark Table, press Search Marks **Clear**.
14. To toggle between showing mark locations in engineering notation or in high precision form, press **Digits**.

Index	Type	Src	Location	Time Delta					Description	
				sec	ms	us	ns	ps		
1	Runt	C1	-109.8us						+Runt	
2	Runt	C1	-79.8us	0	000	03	0	0	+Runt	
3	Runt	C1	0us	0	000	079	0	0	+Runt	
Total Marks: 3				ΔZ1,Z2	0	0	0	0	0	
				ΔZ2,Z3	0	0	0	0	0	
				ΔZ1,Z3	0	0	0	0	0	

15. To toggle the display of mark triangles on and off, select the **View** tab and press **Show Marks**.

16. To stop acquisitions if a match is found, select the **Mode** tab and check **Stop Acquisition if event found**.

Quick Tips.

- Search is performed only on acquired data. Set up the instrument to acquire the data you are searching for.
- Set the sample rate so the search event is discernible. You can search for a glitch that is wider than a couple of sample intervals.
- You can copy trigger settings to search for other locations in your acquired waveform that meet the trigger conditions. You can copy search settings to your trigger.
- Edge search marks are created without zoom factors. Other search types create marks with an appropriate zoom factor.
- Pressing Bring Zoom to Mark **Zoom 2** or **Zoom 3** displays the corresponding zoom view with the same zoom parameters as Zoom 1.
- Custom (User) marks are saved with the waveform when the waveform is saved and when the setup is saved.
- Automatic search marks are not saved with the waveform when the waveform is saved. However, you can easily recapture them by reusing the search function.

- The search criteria are saved in the saved setup.

Search includes the following search capabilities:

Search	Description
Edge	Searches for edges (rising or falling) with a user-specified threshold level.
Glitch	Searches for pulses narrower (or wider) than the specified width, or ignores glitches narrower (or wider) than the specified width.
Pulse Width	Searches for positive or negative pulse widths that are $>$, $<$, $=$, or \neq a user-specified pulse width.
Setup & Hold	Search for violations of user-specified setup and hold times.
Runt	Searches for positive or negative pulses that cross one amplitude threshold but fail to cross a second threshold before crossing the first again. Search for all runt pulses or only those with a duration $>$, $<$, $=$, or \neq a user-specified time.
Window	Searches for a signal that is entering or leaving the threshold window. Qualify the search in terms of time by using the When Wider option, or by the logical state of other channels using the When Logic option.
Pattern	Search for a logic pattern (AND, OR, NAND, or NOR) across multiple waveforms with each input set to either High, Low, or Don't Care. Search for when the event goes true, goes false, or stays valid for $>$, $<$, $=$, or \neq a user-specified time. Additionally, you must define one of the inputs as a clock for synchronous (state) searches.
Transition	Search for rising and/or falling edges that are $>$, $<$, $=$, or \neq a user-specified time.
Timeout	Searches for no pulse in a specified time.
State	Searches for when all of the logic inputs to the selected logic function cause the function to be True or False when the clock input changes state.
DDR Read	Searches for DDR read pulses. Requires option DDRA.
DDR Write	Searches for DDR write pulses. Requires option DDRA.
DDR Read and Write	Searches for DDR read and write pulses. Requires option DDRA.

To Analyze DDR Waveforms:

1. Select **Analyze > DDR Analysis**. Most of the setup can also be done from the Search menus.

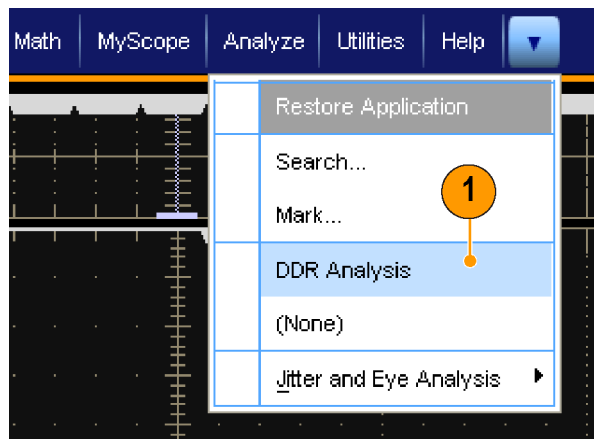

1733-308

2. Select the DDR standard you are using.

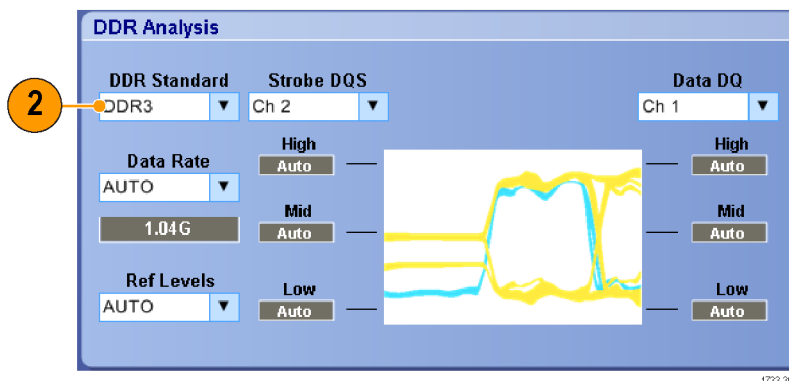

3. Optionally select data rate and reference levels. **AUTO**, the default, calculates the data rate and reference levels for you from the applied signal.
4. From the lists, select the source for both the strobe and data.

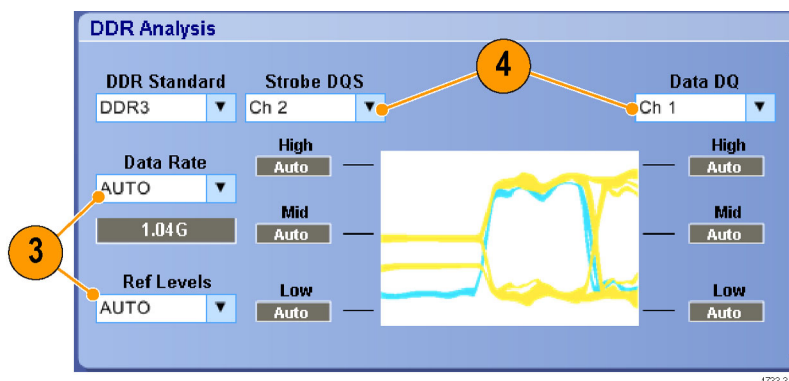

5. Select the type of DDR signal you want to identify.

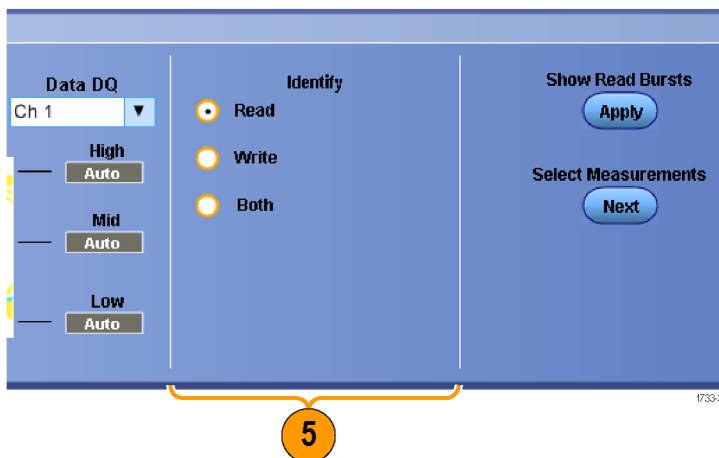

6. Start the search by pressing Show Read Bursts **Apply**.

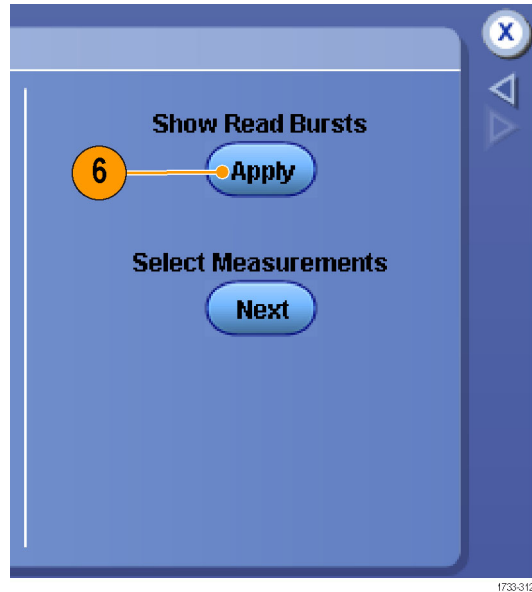

7. On the screen, the gray triangles and line at the top of the graticule show the location of automatic DDR marks. These appear on both normal and zoomed waveform views.

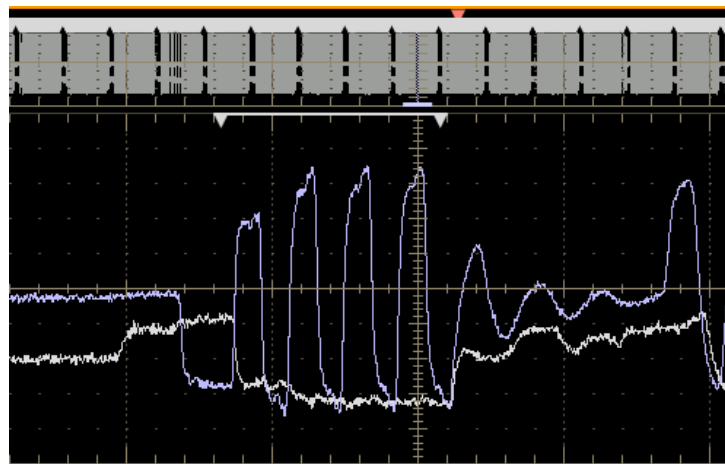

- To further analyze your DDR signal, press Select Measurements **Next** to go to DPOJET.

The advanced measurement package, DPOJET Jitter and Eye Diagram Analysis tool, allows you to measure your DDR signal.

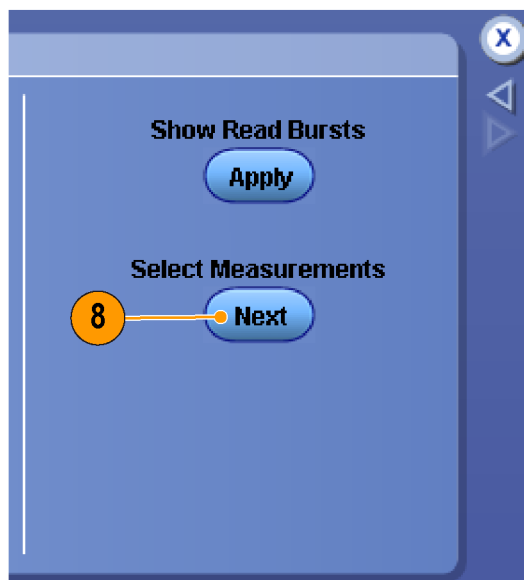

1733-313

- Select a measurement.

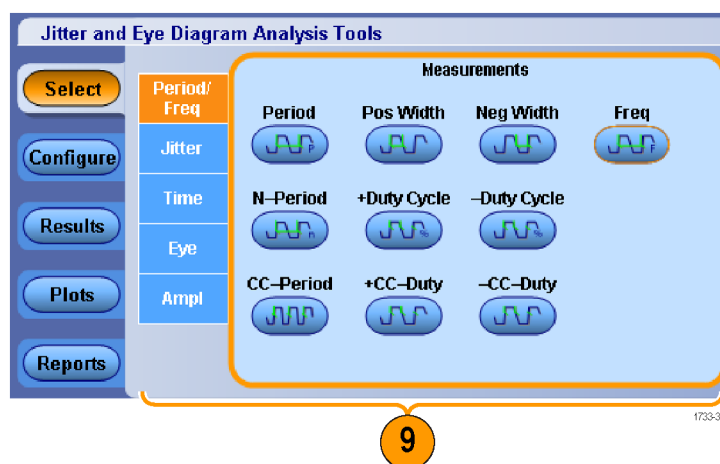

1733-314

10. Select **Configure** > **Global** to qualify or gate with zoom or cursors.



11. If you qualify with logic, select **Configure** and choose the source of logic.
12. Press **OK**.
13. Press **Single** or **Run** to take your measurements.

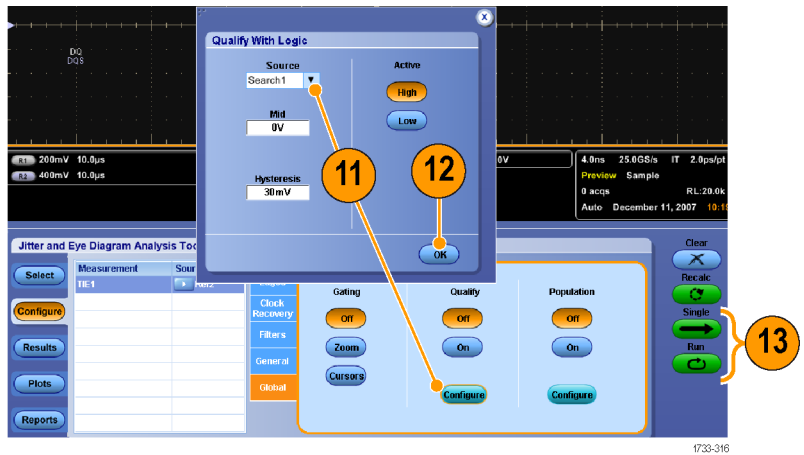

14. View the results of your measurements.
For additional information on using DPOJET, see its online help.

Jitter and Eye Diagram Analysis Tools									
Select	Description	Mean	Std Dev	Max	Min	p-p	Population	Max-cc	Min-cc
▼	Freq1, Ref2	2.1500GHz	85.981MHz	4.5455GHz	1.4252GHz	3.1203GHz	213672	3.0856GHz	-2.8137GHz

Analyzing Waveforms

Your instrument features cursors, automatic measurements, statistics, histograms, math, spectral analysis, and advanced pass/fail tests to assist you in analyzing waveforms. This section contains concepts and procedures for analyzing waveforms. Detailed information is available in the online help.

Taking Automatic Measurements

1. Select **Measure > Measurement Setup...**

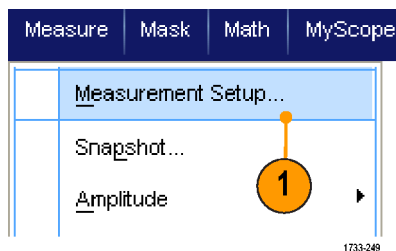

2. Select the channel, math or reference waveform that you want to measure.
3. Using the tabs, select measurements in five different categories.

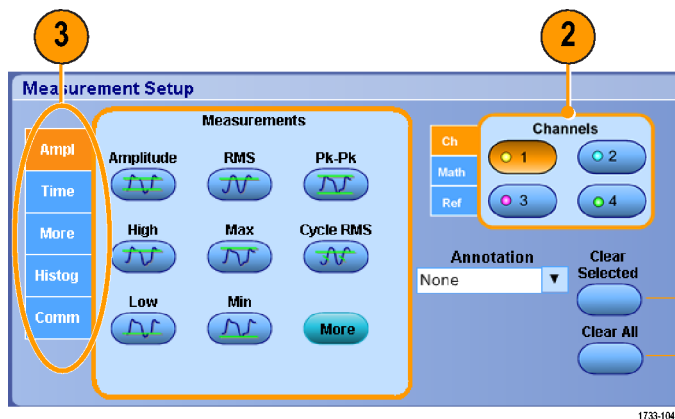

4. To remove all measurements, click **Clear All**.
5. To remove multiple measurements, click and drag to select the measurements, and then click **Clear Selected**.

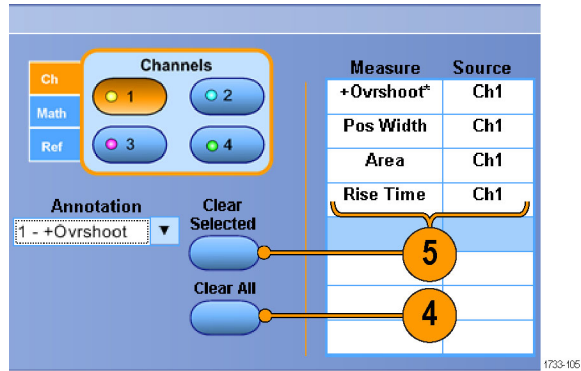

You can also choose a measurement for the selected waveform directly in the Measure menu. (See page 79, *Automated Measurement Selections*.)

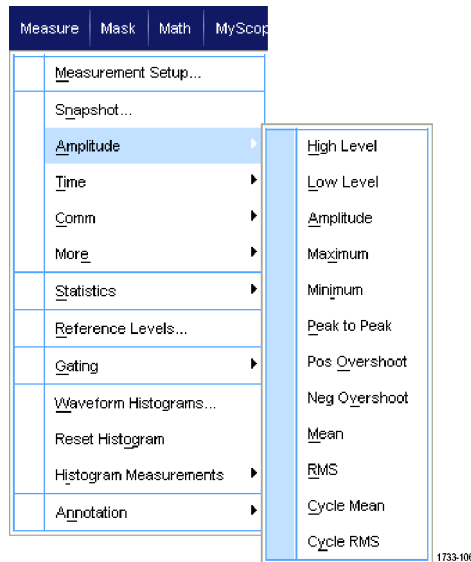

Quick Tips

- In roll mode, measurements are not available until after you stop the acquisition.

Automated Measurement Selections

The following tables list each automated measurement by category: amplitude, time, more, histogram, or communication. (See page 77, *Taking Automatic Measurements.*)

Amplitude Measurements

Measurement	Description
Amplitude	The high value less the low value measured over the entire waveform or gated region.
High	This value is used as 100% whenever high reference, mid reference, or low reference values are needed, such as in fall time or rise time measurements. It can be calculated using either the min/max or histogram method. The min/max method uses the maximum value found. The histogram method uses the most common value found above the midpoint. This value is measured over the entire waveform or gated region.
Low	This value is used as 0% whenever high reference, mid reference, or low reference values are needed, such as in fall time or rise time measurements. It can be calculated using either the min/max or histogram method. The min/max method uses the minimum value found. The histogram method uses the most common value found below the midpoint. This value is measured over the entire waveform or gated region.
RMS	The true Root Mean Square voltage over the entire waveform or gated region.
Max	Typically the most positive peak voltage. Max is measured over the entire waveform or gated region.
Min	Typically the most negative peak voltage. Min is measured over the entire waveform or gated region.
Pk-Pk	The absolute difference between the maximum and minimum amplitude in the entire waveform or gated region.
Cycle RMS	The true Root Mean Square voltage over the first cycle in the waveform or the first cycle in the gated region.
+Overshoot	This is measured over the entire waveform or gated region and is expressed as: Positive Overshoot = $((\text{Maximum} - \text{High}) / \text{Amplitude}) \times 100\%$.
-Overshoot	This is measured over the entire waveform or gated region and is expressed as: Negative Overshoot = $((\text{Low} - \text{Minimum}) / \text{Amplitude}) \times 100\%$.
Mean	The arithmetic mean over the entire waveform or gated region.
Cycle Mean	The arithmetic mean over the first cycle in the waveform or the first cycle in the gated region.

Time Measurements

Measurement	Description
Rise Time	The time required for the leading edge of the first pulse in the waveform or gated region to rise from the low reference value (default = 10%) to the high reference value (default = 90%) of the final value.
Fall Time	The time required for the falling edge of the first pulse in the waveform or gated region to fall from the high reference value (default = 90%) to the low reference value (default = 10%) of the final value.
Pos Width	The distance (time) between the mid reference (default 50%) amplitude points of a positive pulse. The measurement is made on the first pulse in the waveform or gated region.
Neg Width	The distance (time) between the mid reference (default 50%) amplitude points of a negative pulse. The measurement is made on the first pulse in the waveform or gated region.
+ Duty Cyc	The ratio of the positive pulse width to the signal period expressed as a percentage. The duty cycle is measured on the first cycle in the waveform or gated region.

Time Measurements (cont.)

Measurement	Description
- Duty Cyc	The ratio of the negative pulse width to the signal period expressed as a percentage. The duty cycle is measured on the first cycle in the waveform or gated region.
Period	The time required to complete the first cycle in a waveform or gated region. Period is the reciprocal of frequency and is measured in seconds.
Freq	The frequency of the first cycle in a waveform or gated region. Frequency is the reciprocal of the period; it is measured in Hertz (Hz) where one Hz is one cycle per second.
Delay	The time between the mid reference (default 50%) amplitude point of two different waveforms.

More Measurements

Measurement	Description
Area	The area over the entire waveform or gated region in volt-seconds. Area measured above ground is positive; area measured below ground is negative.
Cycle Area	The area over the first cycle in the waveform or the first cycle in the gated region expressed in volt-seconds. The area above the common reference point is positive while the area below the common reference point is negative.
Phase	The amount of time that one waveform leads or lags another waveform, expressed in degrees where 360° comprises one waveform cycle.
Burst Width	The duration of a burst (a series of transient events) and is measured over the entire waveform or gated region.

Histogram Measurements

Measurement	Description
Wfm Ct	Displays the number of waveforms that have contributed to the histogram.
Hits in Box	Displays the number of points in or on the histogram box.
Peak Hits	Displays the number of points in the largest bin of the histogram.
Median	Displays the middle point of the histogram box. Half of all acquired points within or on the histogram box are less than this value and half are greater than this value.
Max	Displays the voltage of the highest nonzero bin in vertical histograms or the time of the rightmost nonzero bin in the horizontal histograms.
Min	Displays the voltage of the lowest nonzero bin in vertical histograms or the time of the leftmost nonzero bin in the horizontal histograms.
Pk-Pk	Displays the peak-to-peak value of the histogram. Vertical histograms display the voltage of the highest nonzero bin minus the voltage of the lowest nonzero bin. Horizontal histograms display the time of the rightmost nonzero bin minus the time of the leftmost nonzero bin.
Mean	Measures the average of all acquired points within or on the histogram box.
Std Dev	Measures the standard deviation (Root Mean Square (RMS) deviation) of all acquired points within or on the histogram box.
Mean \pm 1 Std Dev	Displays the percentage of points in the histogram that are within one standard deviation of the histogram mean.

Histogram Measurements (cont.)

Measurement	Description
Mean ± 2 Std Dev	Displays the percentage of points in the histogram that are within two standard deviations of the histogram mean.
Mean ± 3 Std Dev	Displays the percentage of points in the histogram that are within three standard deviations of the histogram mean.

Communication Measurements

Measurement	Description
Ext Ratio	The ratio of eye top to base. This measurement only works for waveform database or a reference waveform saved in waveform database mode.
Ext Ratio %	The ratio of eye base to top expressed as a percentage. This measurement only works for waveform database or a reference waveform saved in waveform database mode.
Ext Ratio (dB)	The ratio of eye top to base expressed in decibels. This measurement only works for waveform database or a reference waveform saved in waveform database mode.
Eye Height	The measurement of the eye height in volts.
Eye Width	The measurement of eye width in seconds.
Eye Top	The top value used in the extinction ratio measurements.
Eye Base	The base value used in the extinction ratio measurements.
Crossing %	The eye crossing point expressed as a percentage of eye height.
Jitter P-P	The peak-to-peak value for the edge jitter in the current horizontal units.
Jitter RMS	The RMS value of the edge jitter in the current horizontal units.
Jitter 6 Sigma	Six times the RMS value of the edge jitter in the current horizontal units.
Noise P-P	The peak-to-peak value of the noise of the top or base of the signal as specified by you.
Noise RMS	The RMS value of the noise of the top or base of the signal as specified by you.
S/N Ratio	The ratio of the signal amplitude to the noise of the top or base of the signal as specified by you.
Cyc Distortion	The peak-to-peak time variation of the first eye crossing measured at the Mid Ref as a percent of the eye period.
Q-Factor	The ratio of eye size to noise.

Customizing an Automatic Measurement

You can customize automatic measurements by using gating, modifying measurement statistics, or adjusting the measurement reference levels.

Gating

Use Gating to confine the measurement to a certain portion of a waveform.

1. Select **Measure > Gating > Gating**
2. Position the gates by doing one of the following:
 - Click **Cursor** to set the gated area to the area between the cursors.
 - Click **Zoom (1-4)** to set the gated area to the Zoom (1-4) graticule.

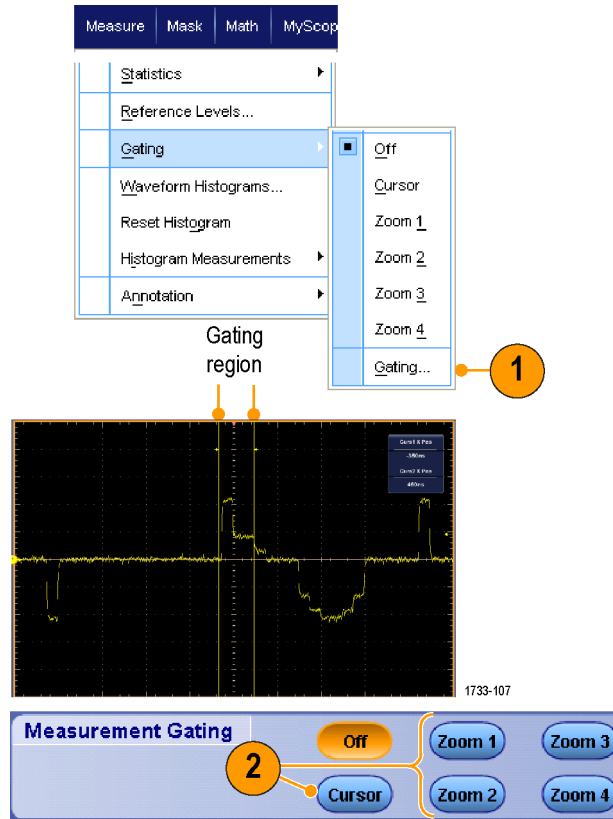

Statistics

Statistics turn on automatically with measurements. Statistics characterize the stability of the measurement.

1. To change the statistics that are displayed, select **Measure > Statistics**, and then select **Mean** or **All**. (All includes min, max, mean, standard deviation, and population.)
2. To remove statistics select **Off**.

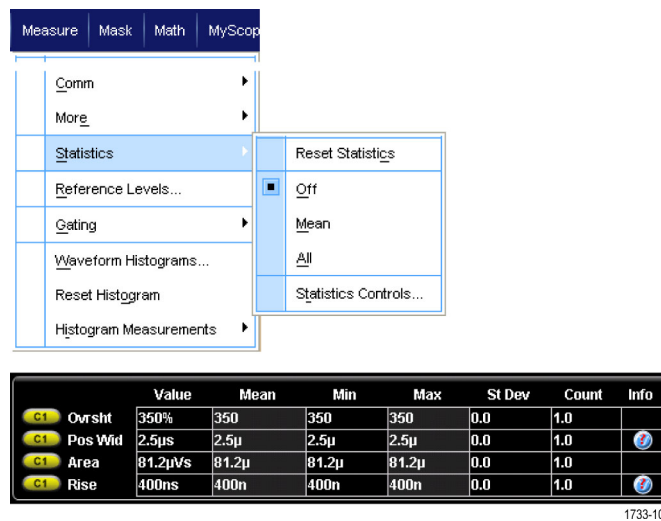

Snapshot

To see a one-time view of all valid measurements, select **Measure > Snapshot**.

NOTE. If the setup for a measurement is invalid, the results of that measurement is displayed as 3 question marks.

Measurement Setup...

Snapshot...

Amplitude

Time

1

Period	28.65µs	Freq	34.91kHz
Pos Width	13.53µs	Neg Width	15.12µs
Burst Mid	86.0µs		
Rise Time	62.69ns	Fall Time	67.52ns
+ Duty Cyc	47.22%	- Duty Cyc	52.78%
+ Overshoot	5.21%	- Overshoot	6.25%
Max	632 mV	High	592 mV
Min	-224 mV	Low	-176 mV
Amplitude	768 mV	Pk-Pk	856 mV
Mean	179.99mV	Cycle Mean	184.04mV
RMS	423.53mV	Cycle RMS	425.91mV
Area	17.98µVs	Cyc Area	6.27µVs

1733-253

To select between taking a snapshot of general measurements or communications measurements, select General or Comm.

Measurement Snapshot on Ch 1

Period	???	Freq	???
Pos Width	497.33ns	Neg Width	???
Burst Mid	506.67ns		
Rise Time	275.41ns	Fall Time	???
+ Duty Cyc	???	- Duty Cyc	???
+ Overshoot	3.66%	- Overshoot	2.03%
Max	248 mV	High	230 mV
Min	-272 mV	Low	-262 mV
Amplitude	492 mV	Pk-Pk	520 mV
Mean	-12.46mV	Cycle Mean	???
RMS	176.41mV	Cycle RMS	???
Area	-12.45µVs	Cyc Area	???

Measurement Context

Base, Top Form Histogram

High Ref 90.0%

Mid Ref 50.0%

Low Ref 10.0%

Refresh

Snapshot Type

General Comm Setup

2

1733-250

Annotate Measurements

1. To annotate measurements, select **Annotation** from the Measurements setup control window. From the drop down list, select the measurement to annotate.

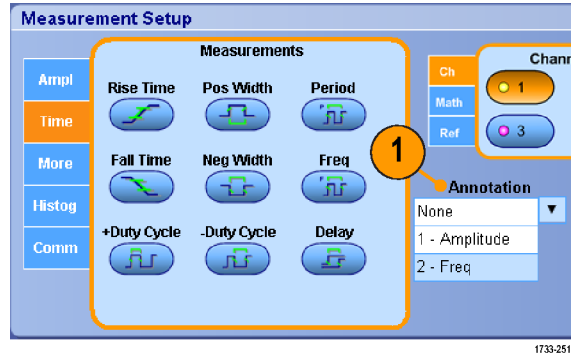

2. To select the amount of measurement annotation detail, select **Measure > Annotation > Standard** or **Detailed**.

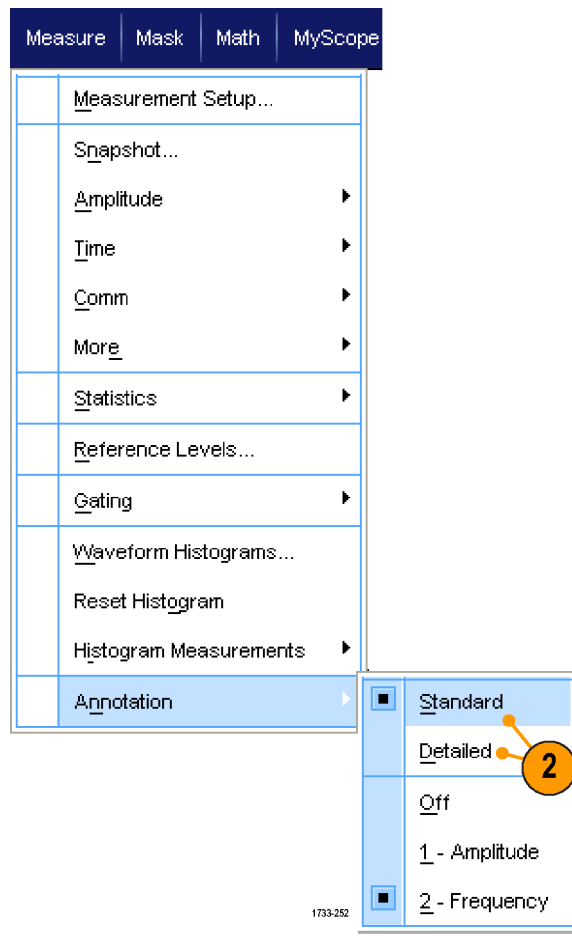

Reference Levels

Reference levels determine how time-related measurements are taken.

1. Select **Measure > Reference Levels....**
2. Adjust the measurement reference levels to different relative or absolute values.
 - High and Low references are used to calculate rise and fall times. The default High reference is 90% and Low reference is 10%.
 - Mid reference is primarily used for measurements between edges such as pulse widths. The default level is 50%.
 - Mid2 reference is used on the second waveform specified in delay or phase measurements. The default level is 50%.

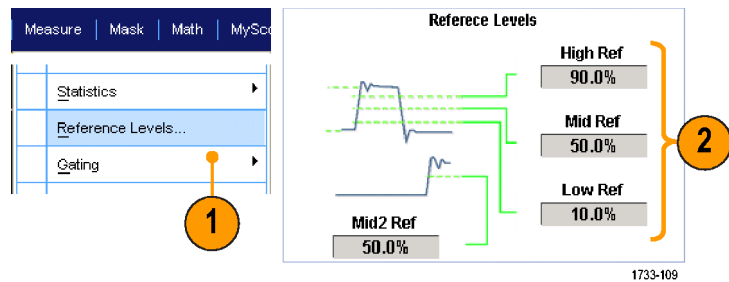

Quick Tips

- To ensure accurate noise values, be sure to set the signal type to Eye when measuring an Eye signal.

Taking Cursor Measurements

Use cursors to taking measurements on acquired data.

1. Push **Cursors**.

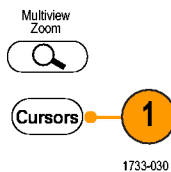

2. Select the Cursor Source.

3. Select a cursor type from one of the following:

- H Bars measure amplitude (typically in volts or amperes)
- V Bars measure horizontal parameters (typically time)
- Waveform and screen cursors measure vertical and horizontal parameters simultaneously. Waveform cursors are attached to the waveform, and screen cursors float, unattached to the waveform.

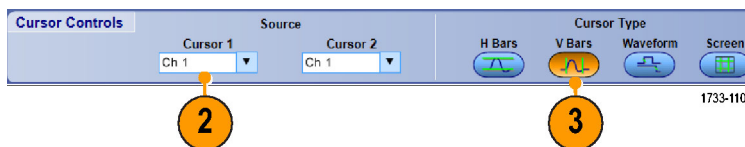

- To take measurements between two waveforms, select **Waveform**, and then select the waveform source for each cursor.

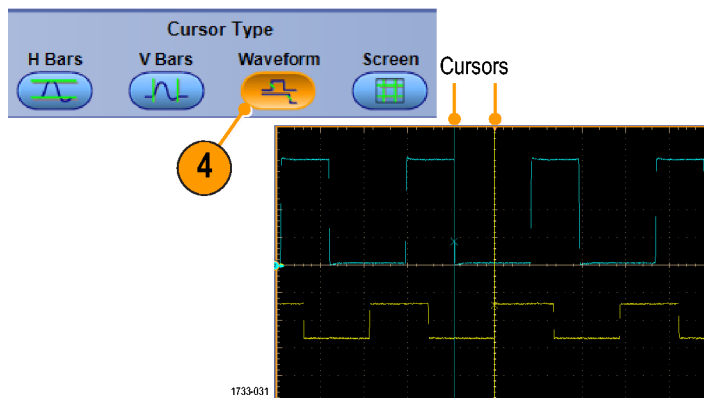

- Select **Cursors > Cursor Position...**, and then use the multipurpose knobs to adjust the cursor position.
- Read cursor measurement results in the display.

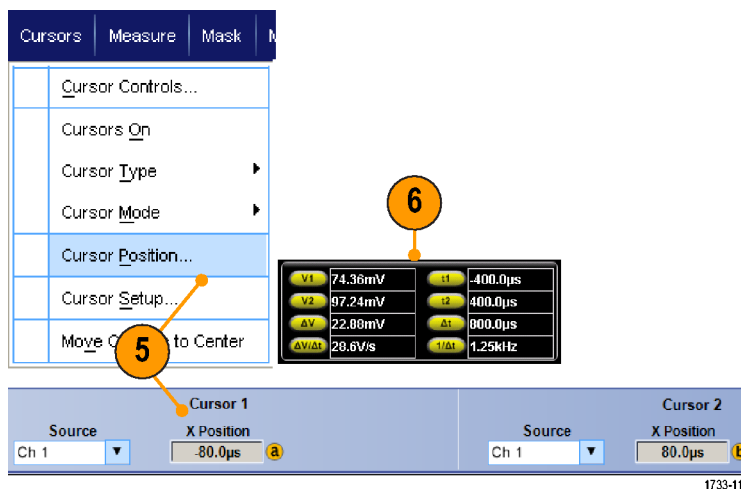

Quick Tips

- Use the Cursor Track Mode to set the cursors to move in tandem. Use the Cursor Independent mode to move the cursors separately.
- If you use the zoom graticule, you can place a cursor directly on a specific waveform point to take precision measurements.
- You can also move cursors by clicking and dragging them to a new position.
- You can also move cursors to the center of the display by pressing **Move Cursors to Center**.
- You can select solid or dashed cursors.
- Vertical cursors measure the time from the trigger point to the vertical cursor.

Setting Up a Histogram

You can display either a vertical (voltage) or horizontal (time) histogram. Use histogram measurements to get statistical measurement data for a section of a waveform along one axis.

1. Click and drag the pointer across the segment of the waveform that you want the histogram to cover. For example, make the box for a horizontal histogram wider than it is tall.
2. Select **Histogram Vertical** or **Histogram Horizontal** from the shortcut menu.

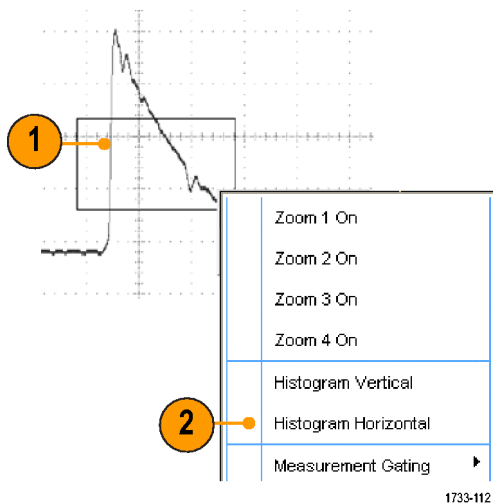

1733-112

3. View the histogram at the top (for horizontal histograms) or the left edge (for vertical histograms) of the graticule.

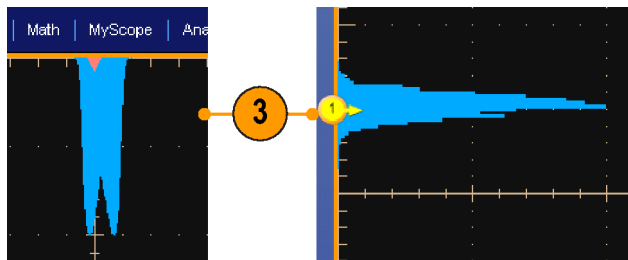

1733-113

4. To make adjustments to the histogram scale or the size and location of the histogram box, select **Measure > Waveform Histograms**, and then use the Histogram Setup control window.
5. You can also take automated measurements on histogram data. (See page 77, *Taking Automatic Measurements*.)

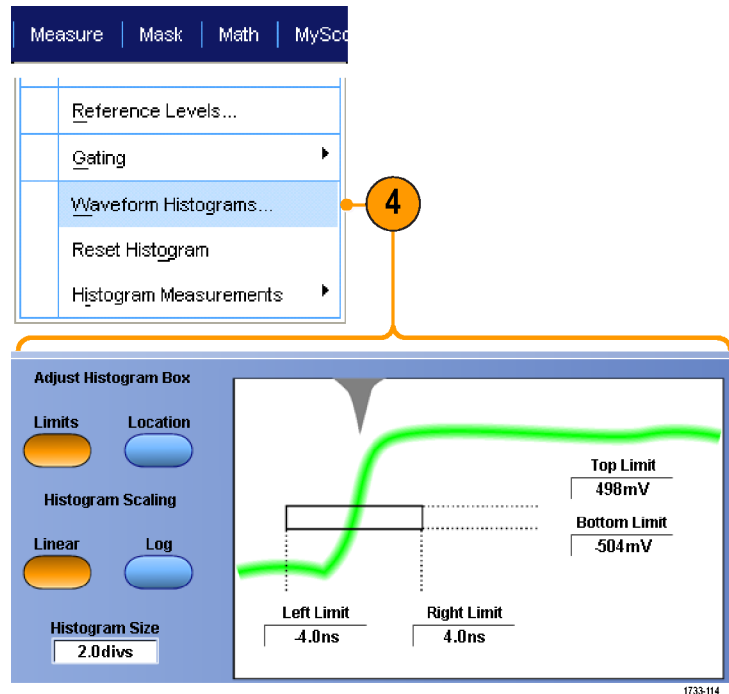

Quick Tips

- Use vertical histograms to measure signal noise and horizontal histograms to measure signal jitter.
- Use the click and drag procedure to activate the shortcut menu to turn the histogram display off.

Using Math Waveforms

Create math waveforms to support the analysis of your channel and reference waveforms. By combining and transforming source waveforms and other data into math waveforms, you can derive the data view that your application requires.

Use the following procedure for predefined math equations.

1. Select **Math > Math Setup...**

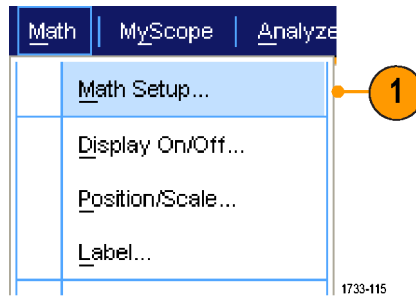

2. Choose one of the predefined math equations.

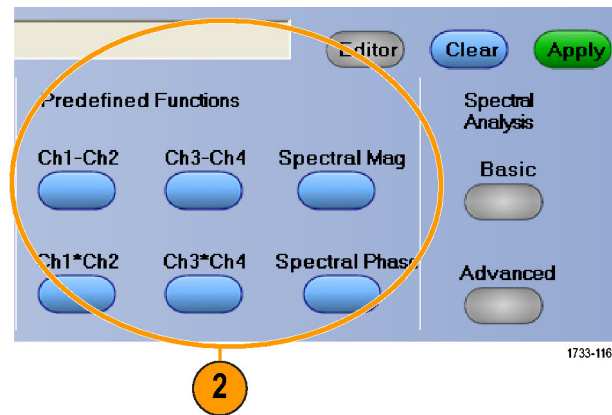

Use the following procedure to build an advanced math waveform expression.

1. Select **Math > Math Setup...**

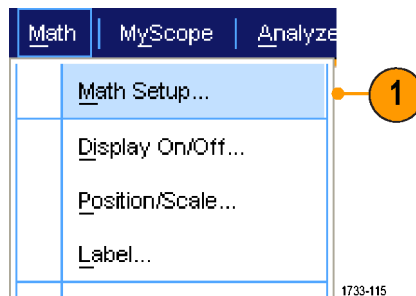

2. Click **Editor**.

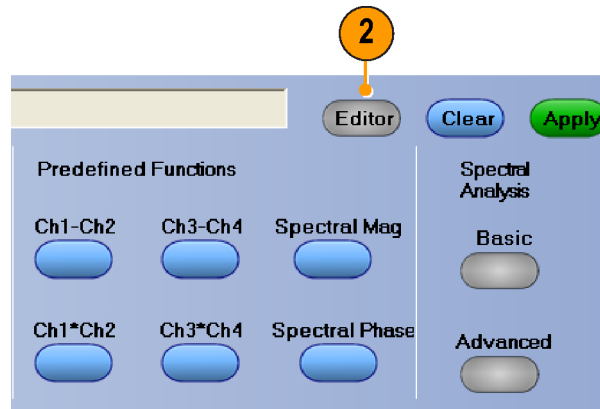

1733-117

3. Build your advanced math waveform expression using sources, operators, constants, measurements, variables, and functions.
4. When you have defined the expression to your satisfaction, click **Apply**.

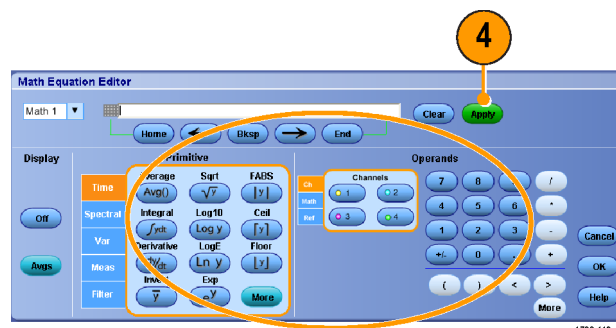

1733-118

5. To add your own filter, click the **Filter** tab. Click **Load**.

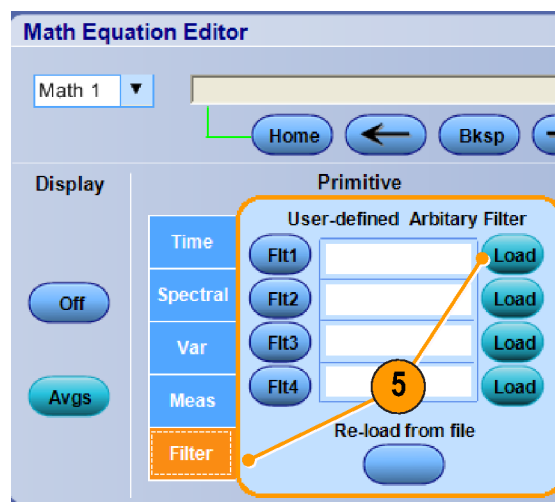

1733-219

6. Double click the folder for the filters you want to use. Double click the filter you want to use.

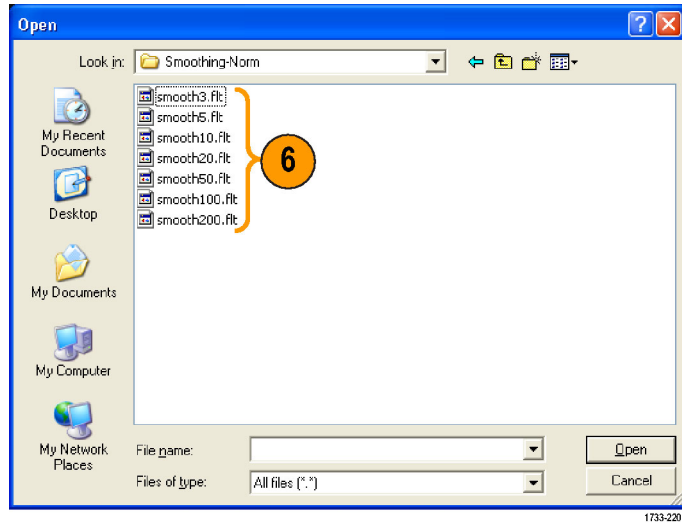

7. Build your math expression using the filter you selected.
8. When you have defined the expression to your satisfaction, click **Apply**.

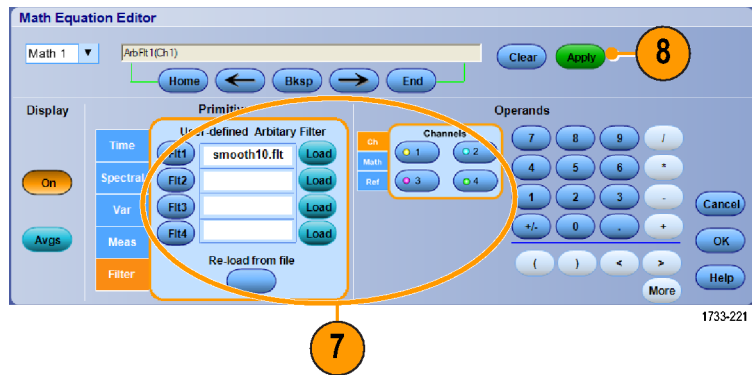

Quick Tips

- Math definitions are not implemented if the sources are not valid.
- Math waveforms can be created from channel, reference, math source waveforms and from measurements.
- Measurements can be taken on math waveforms in the same way as on channel waveforms.
- Math waveforms derive their horizontal scale and position from the sources in their math expressions. Adjusting these controls for the source waveforms also adjusts the math waveform.
- You can magnify math waveforms using MultiView Zoom; use the mouse for positioning the zoomed area.
- See the online help for more information on arbitrary math filters.

Using Spectral Analysis

Use the following procedure for predefined spectral math expressions. See the online help for more information.

1. Select **Math > Math Setup...**

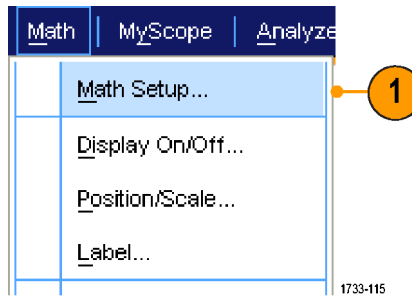

2. Choose one of the predefined spectral math expressions.
3. Click **Basic**.

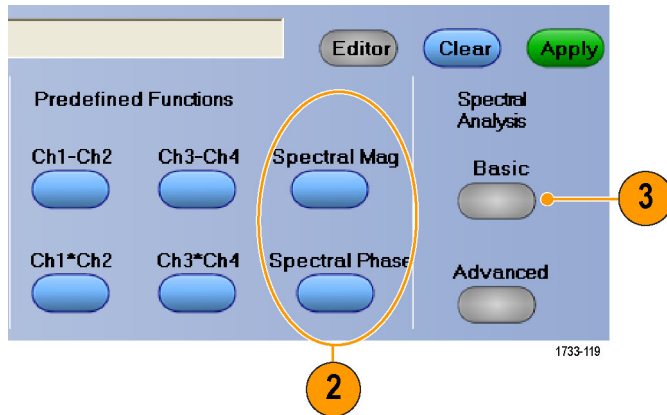

4. Click Resolution BW or Frequency Span and use the keypad or the multipurpose knobs to adjust the spectral display.

NOTE. Resolution BW and Frequency Span are only adjustable in Manual Horizontal Mode.

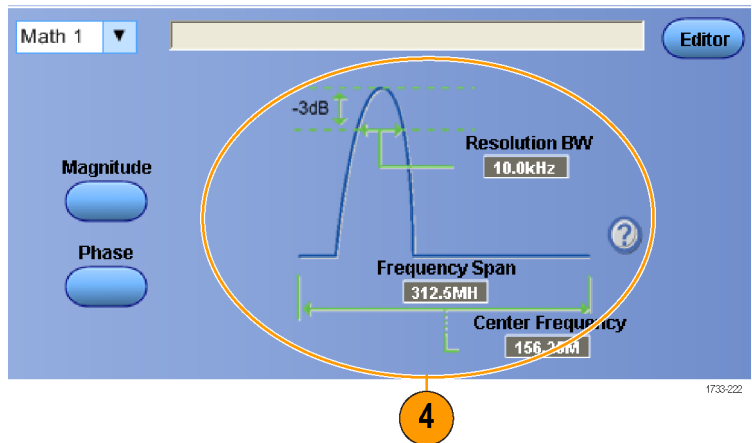

Use the following procedure to build an advanced spectral math expression.

1. Select **Math > Advanced Spectral...**

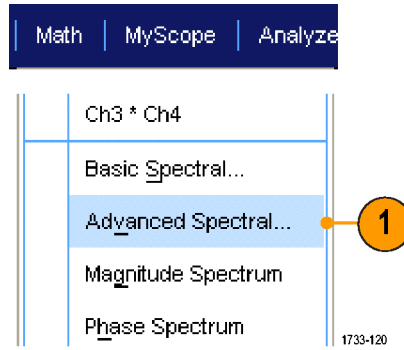

2. Select the math waveform that you want to define.
3. Click the type of spectral waveform that you want to create. To redefine a waveform, click Clear.
4. Select the source waveform.
5. Adjust the spectral waveform, using the controls in the Spectral Setup control window and use the multipurpose knobs.

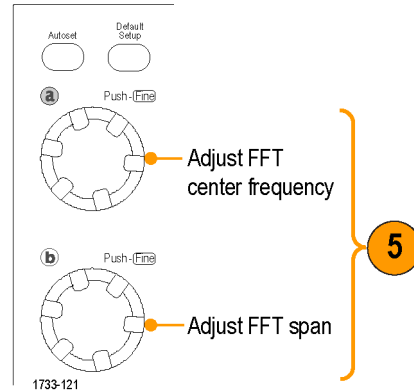
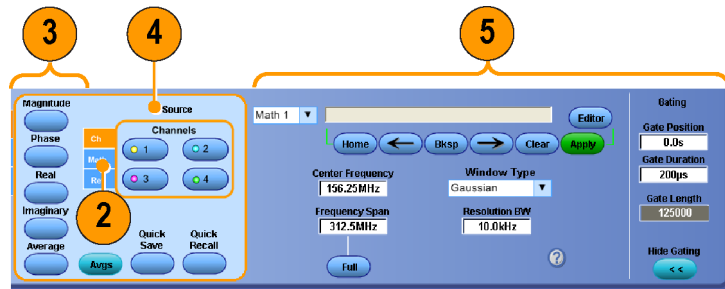

6. You can view time-domain and frequency-domain waveforms simultaneously.
Use **Gating** to select only a portion of the time-domain waveform for spectral analysis. (See page 82, *Gating*.)

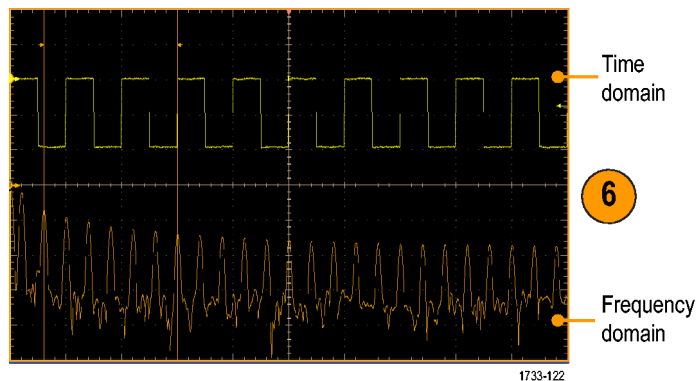

Quick Tips

- Sources for spectral math waveforms must be channel or other math waveforms.
- Use short record lengths for faster instrument response.
- Use long record lengths to lower the noise relative to the signal and increase the frequency resolution.
- Different window functions produce different filter response shapes in the spectrum and result in different resolution bandwidths. See the online help for more information.
- The resolution bandwidth (RBW) directly controls the gate width. Therefore, the time domain gate markers move as you adjust the control.
- You can display the linear magnitude of the real data or the imaginary data in the spectrum. This is useful if you process the spectrum off line and transform it back into a time domain trace.

Using Mask Testing

Serial Communications Mask Testing (Option MTM or MTH) allows you to compare your signal to a predefined template or mask. For the signal to pass the test, it must fall outside the segments defined by the mask. Generally, standards committees such as ANSI define the masks. To perform mask testing do the following:

1. Select **Masks > Source...**

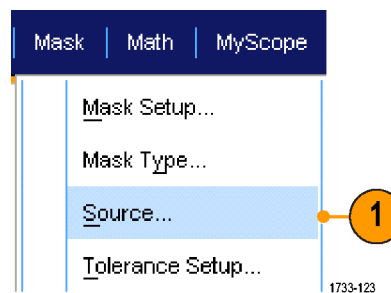

2. Select the signal source.

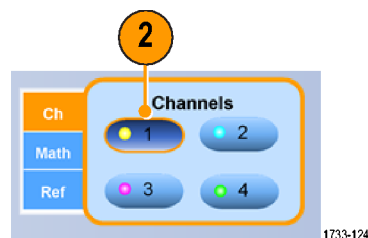

3. Click the **Masks** tab.

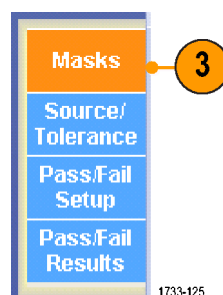

- Select the Type and standard.

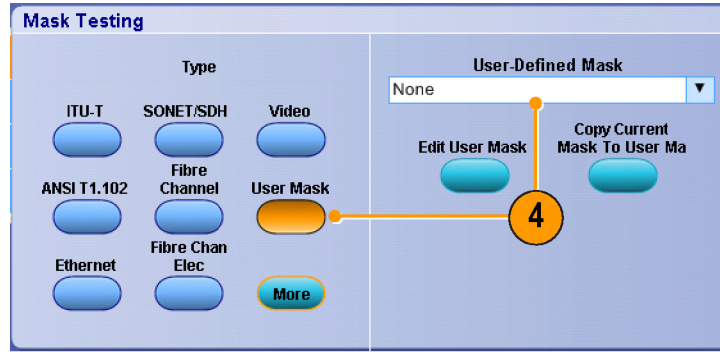

1733-126

- Click **Config** to access the Mask Configuration control window, where you can adjust how masks and violations are displayed and how Mask Autoset and Autofit are configured.
- Click **Masks** to return to the Mask Setup control window.

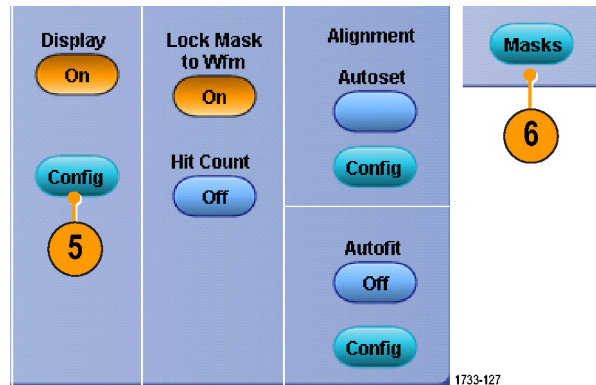

1733-127

- Click Lock Mask to Wfm **On** to track mask changes in the horizontal or vertical settings.
- Toggle Hit Count **On** to highlight violations during a mask test.

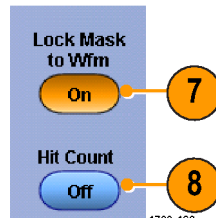

1733-128

- Click **Autoset** to automatically align the waveform with the mask based on the characteristics of the input signal.
- Toggle Autofit **On** to automatically reposition the waveform after each acquisition to minimize hits.

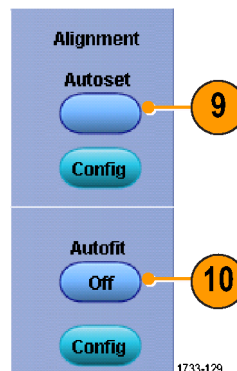

1733-129

11. Click the **Tolerance** tab, and then set the tolerance.

Tolerance settings greater than 0% make the mask test harder to pass, settings less than 0% make the test easier to pass.

Use 0% if you want the mask as specified in the standard. Changing the percentage allows you to do margin testing.

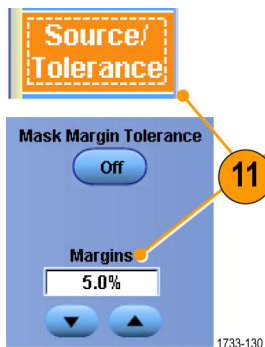

12. Select the **Pass/Fail Setup** tab, and then set up the pass/fail parameters. (When acquisition mode is Waveform Database, the # of Wfms label becomes Samples.)

13. Select your Pass/Fail Test Notifications.

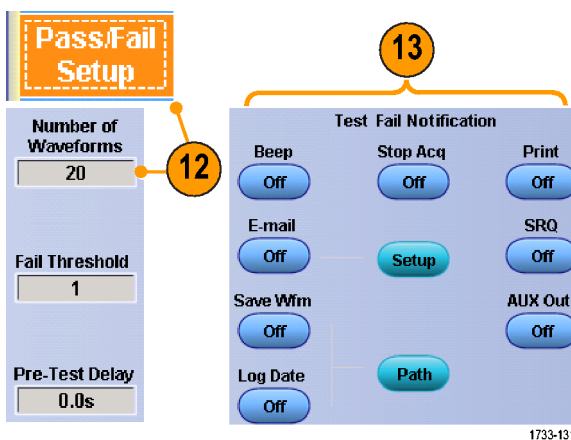

14. Select the polarity you want to test.
15. Toggle Pass/Fail Test **On** to start the mask test.
16. Toggle Repeat **On** to run the mask test continuously.
17. Select the notification you want when the test is complete.

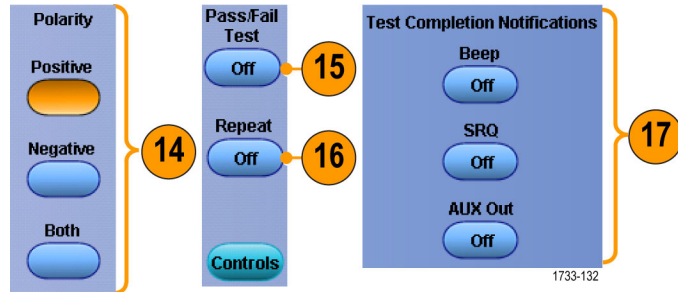

18. Click the **Pass/Fail Results** tab to view the test results.
19. Click Pass/Fail Test **On** to start the mask test.
20. Click **Reset** to reset the totals and clear any violations.

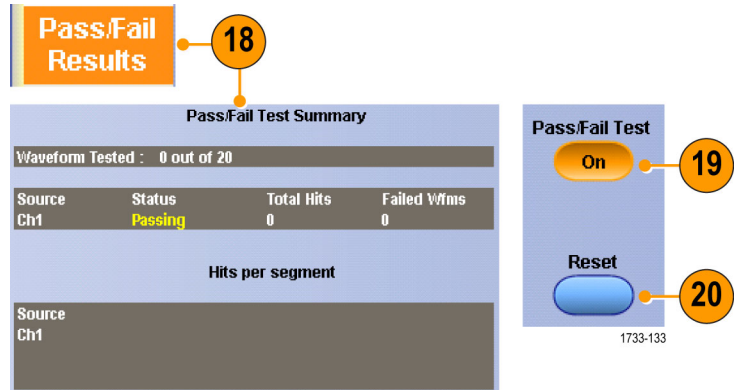

Quick Tips

- If the signal is not within the mask, enable Autoset to center the waveform in the mask.

Using Limit Testing

Optional limit testing allows you to compare an active signal with a template waveform. Build your template waveform from a known good signal and use it to compare to an active signal to perform pass/fail testing.

1. Select **Masks > Limit Test Setup...**

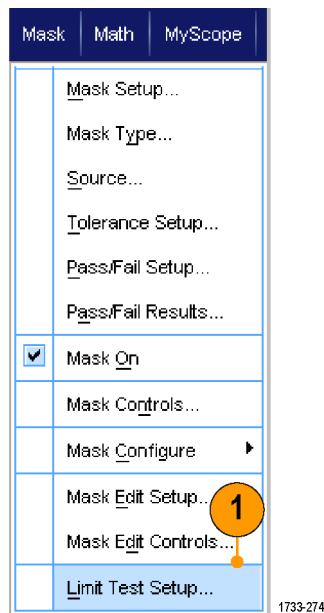

2. Create the template by selecting the Source, Destination, and Tolerances. Use the multipurpose knobs to adjust the Tolerances. Tolerances specify how much margin the signal is allowed before failing the limit test.

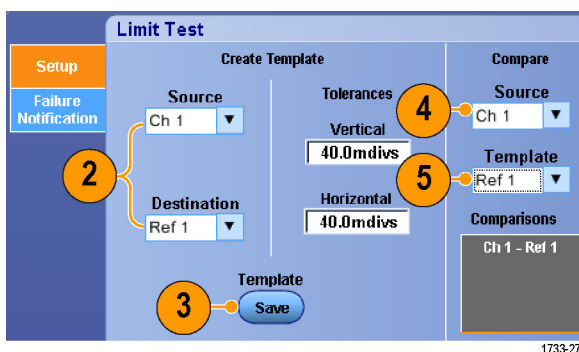

3. Click **Save**. You can create multiple templates and save them for later use.
4. Select the source waveform to compare to the template.
5. Select the template to compare to the Source waveform. (Usually, this is the template that you created in step 3.)

6. Click **Failure Notification** to set up the Failure Notification.

7. Select the Failure Notification(s), and then click **Setup** to return to the setup control window.

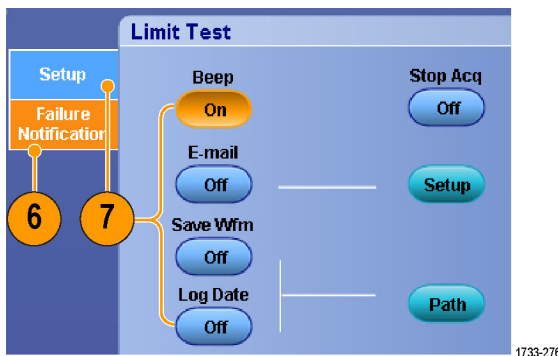

8. Click Lock Template to Waveform **On** to lock the vertical scale or position of the template to that of the source waveform.
9. Click Highlight Hits **On** to show points that fall outside the template in a different color.

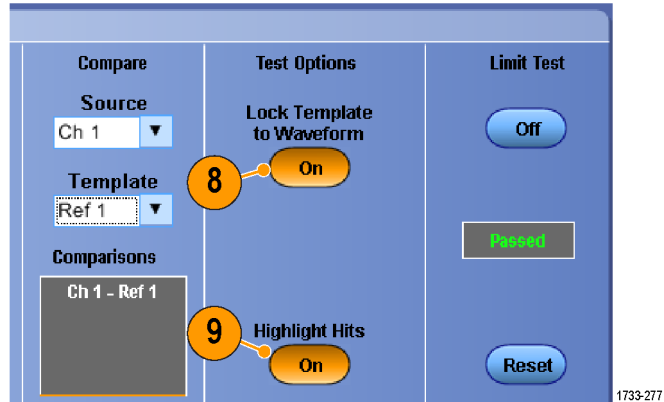

10. Toggle Limit Test to **On** to start the test.
11. Click **Reset** to clear all violations and reset the test.

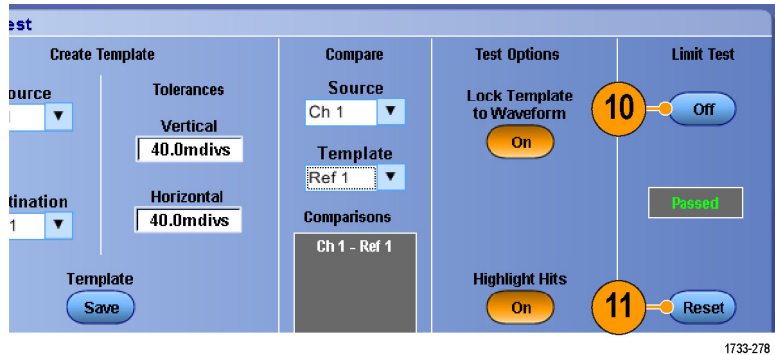

Quick Tips

- You can use active or saved waveforms to create a limit test template.
- Using Average acquisition mode will create a smoother template waveform.
- Using Envelope acquisition mode will create a template that allows for occasional overshoots.

MyScope

MyScope allows you to create custom control windows that include only the controls that you use regularly. Instead of switching between several control windows, put the controls you use into a custom control window.

This section contains procedures for creating and using MyScope control windows. Detailed information is available in the online help.

Creating a New MyScope Control Window

1. Select **MyScope > New Control Window....**

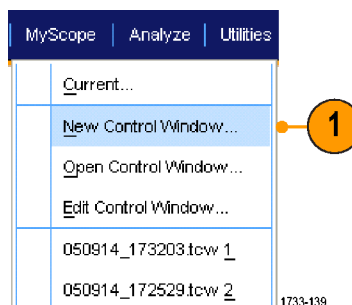

2. Click + to expand a category. Controls that can be added to your MyScope control window are contained within each category. The categories match the menu bar to help you find the controls you normally use.

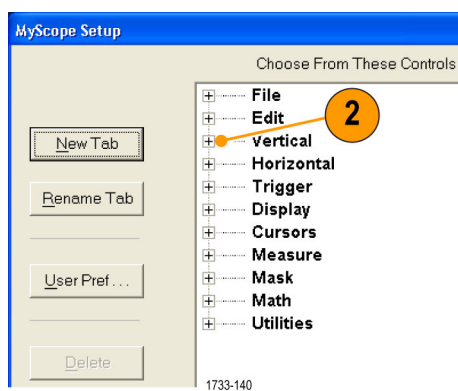

3. Click a control to preview it.

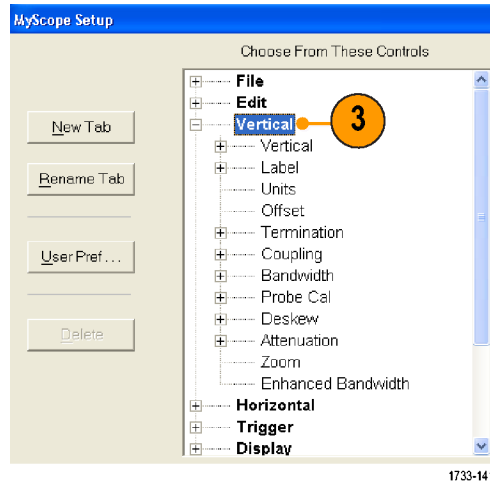

4. Double-click the control or click the + to expand the control list. (If there is no +, then the control cannot be customized further.)

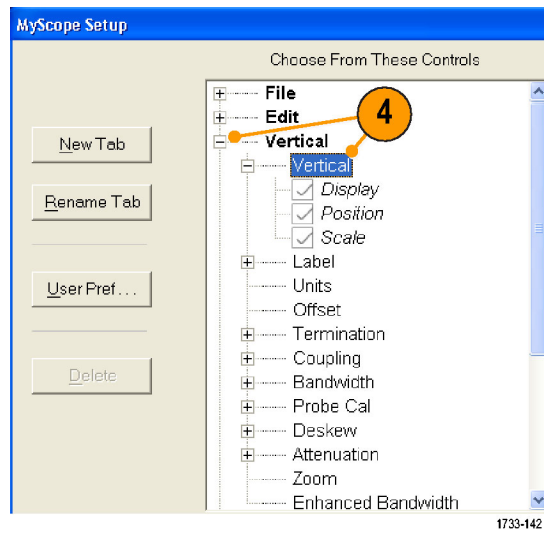

5. Clear the check boxes to remove any components that you do not want included in the control.

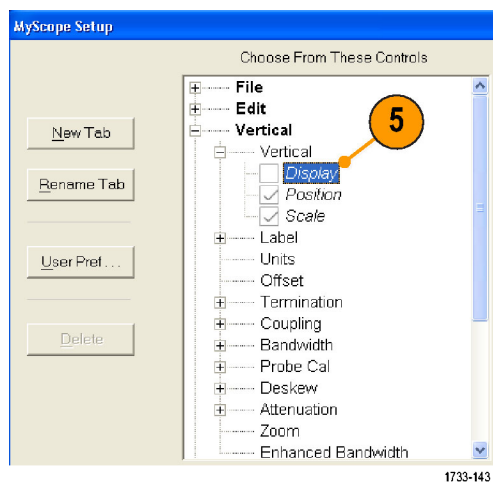

6. Click and drag the control to your MyScope control window. The control will snap to the nearest grid location when you release the mouse. You can change the placement of the control in your MyScope control window by clicking and dragging.

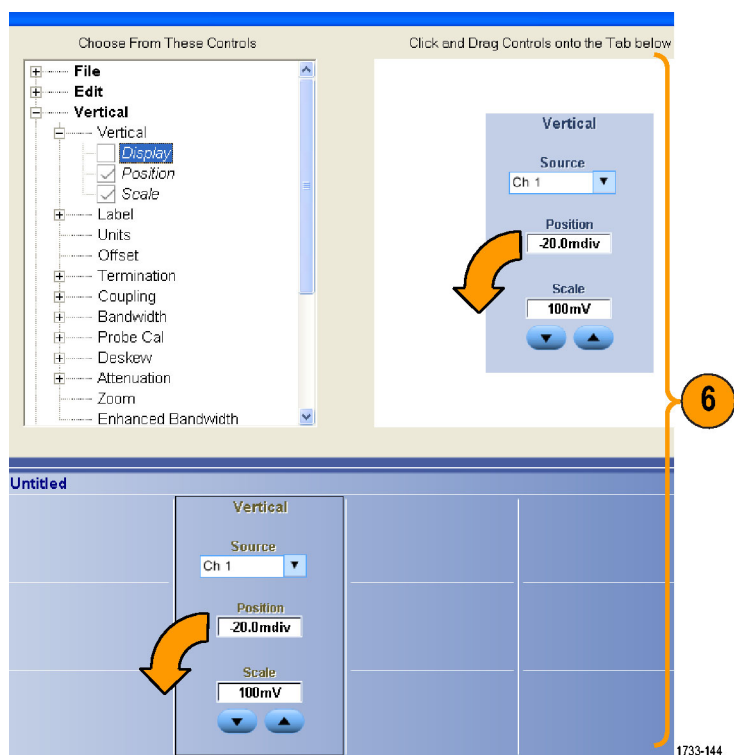

7. Click **New Tab** to add a tab to your MyScope control window. You can have up to six tabs.

8. To rename a tab do one of the following:

- Click **Rename Tab**.
- Double-click the tab, and then type the new name.

9. Click **User Pref...** to specify user preferences that are loaded with your MyScope control window.

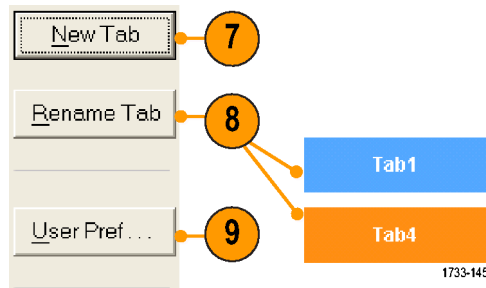

10. To delete controls do one of the following:

- Select a tab, and then click **Delete**. The tab and all of the controls are deleted.
- Select a control, and then click **Delete**. Just the selected control is deleted.

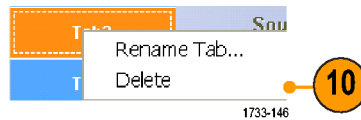

11. Click **Save**, and then enter a name for your MyScope control window, or use the default name.

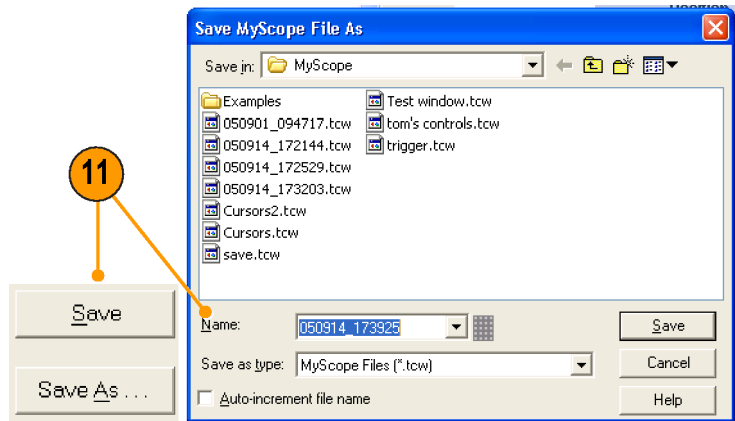

Quick Tips

- To reconfigure a control, click and drag it back to the preview window. Then select or clear the check boxes to include or remove components in the control.
- To change the tab order, click and drag a tab to a new location.
- To delete a control, click and drag it to the upper half of the screen (out of your MyScope control window).

Using MyScope Control Windows

To open a previously defined MyScope control window, do the following:

1. Select **MyScope > Open Control Window...** or one of the five most recently used MyScope windows.

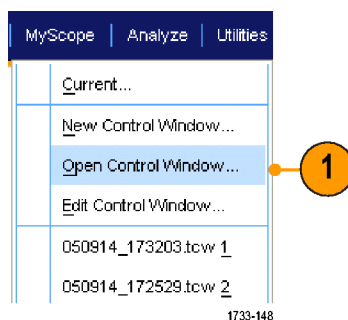

2. Select the MyScope control window you want to use, and then click **Open**.

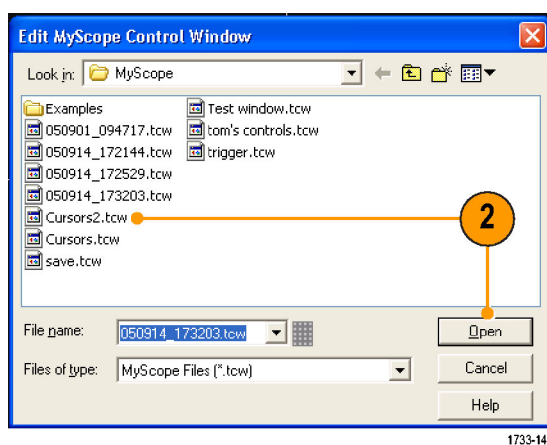

To display the active MyScope control window, do the following:

1. Select **MyScope > Current...** or click **MyScope** in the toolbar mode. (Your MyScope control window remains active even when it is not displayed.)

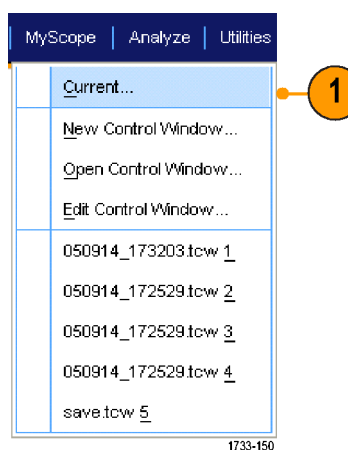

To edit a MyScope control window do the following:

1. Select **MyScope > Edit Control Window...**

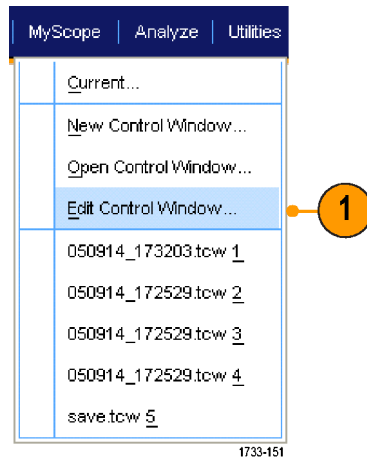

2. Select the control window you want to edit, and then click **Open**.

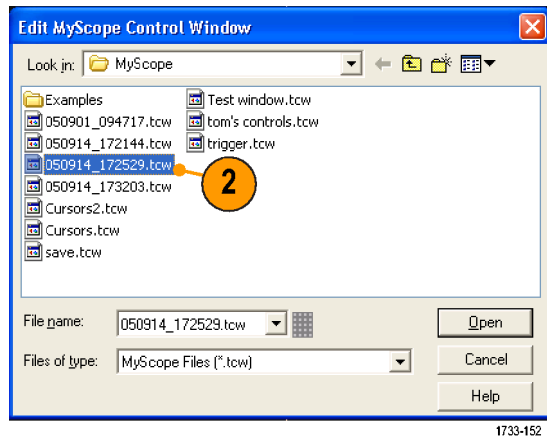

Quick Tips

- Some controls function differently in a MyScope control window than they do in the standard control window. For details, see the online help.
- You can copy MyScope control windows (.tcw files) to other DPO7000 Series instruments.

Saving and Recalling Information

This section contains procedures for saving and recalling screen captures and setups, saving measurements, using the clipboard, and printing on your instrument. Detailed information is available in the online help.

Saving Screen Captures

1. Select **File > Save or Save As > Screen Capture...**

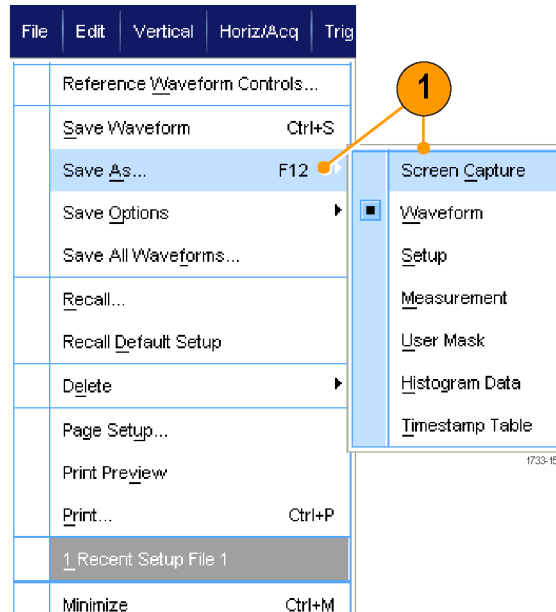

2. Click **Options...**, if you want to setup the Palette, View, Image, or Screen Capture Format options; otherwise, skip to step 3.

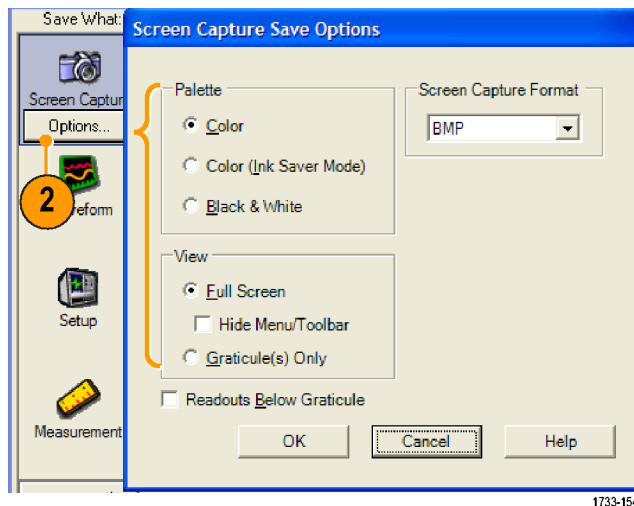

3. Select the location to save the screen capture.
4. Type in a name for the screen capture, or use the default name, and then select a file type.
5. Click **Save**.

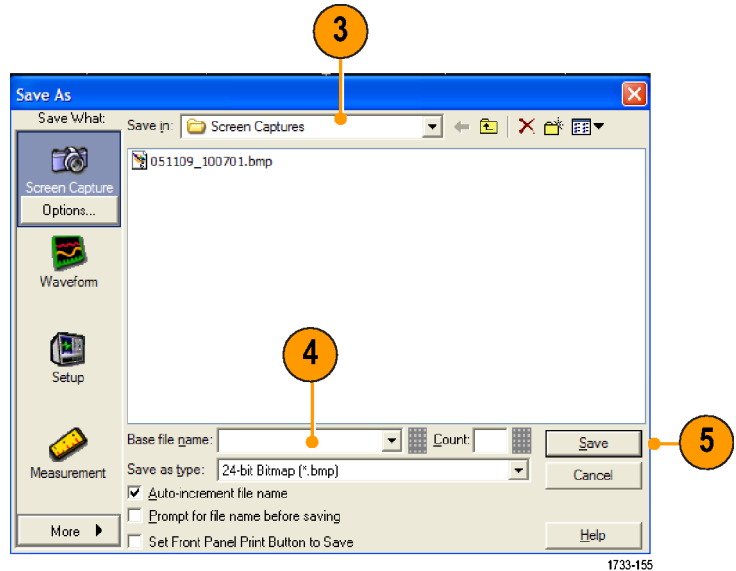

Quick Tip

- To quickly save multiple screen captures, select **Set Front Panel Print Button to Save**, and then click Save. You can now save a screen capture by pushing the front panel Print button.

Saving Waveforms

1. To save waveforms, select **File > Save** or **Save As > Waveform...**

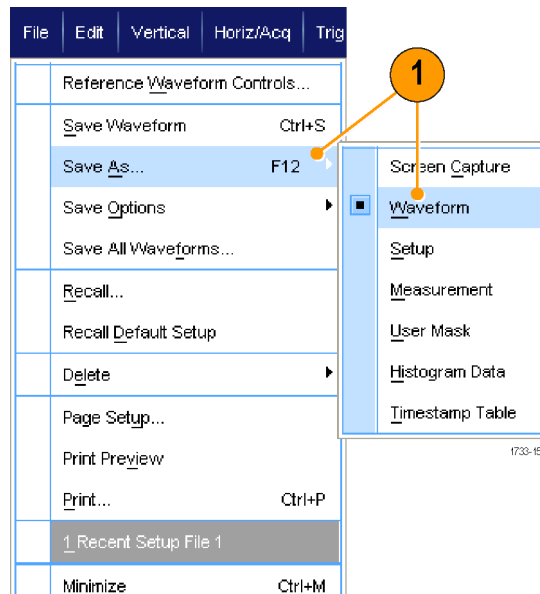

2. Click **Waveform**.
3. Click **Options...**, if you want to specify the Waveform Data Range, FastFrame Data Range, Waveform Detail, Data Destination, Source, or Data Ordering; otherwise, skip to step 4.

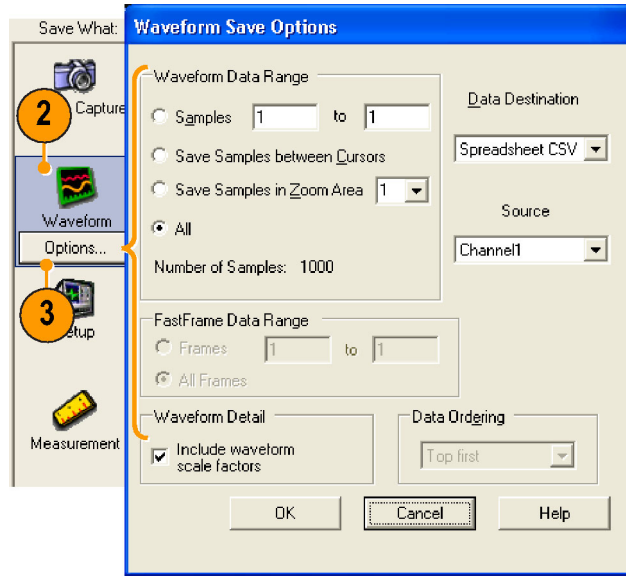

1733-157

4. Select the Source.
5. You can either save the waveform as a reference waveform in the instrument memory or as a .wfm file in a Windows directory. To save the waveform as a reference, select Ref 1–4. To save as a .wfm file, select the location where you want to save the waveform.
6. If you are saving as a .wfm file, type in a file name, or use the default.
7. Click **Save**.

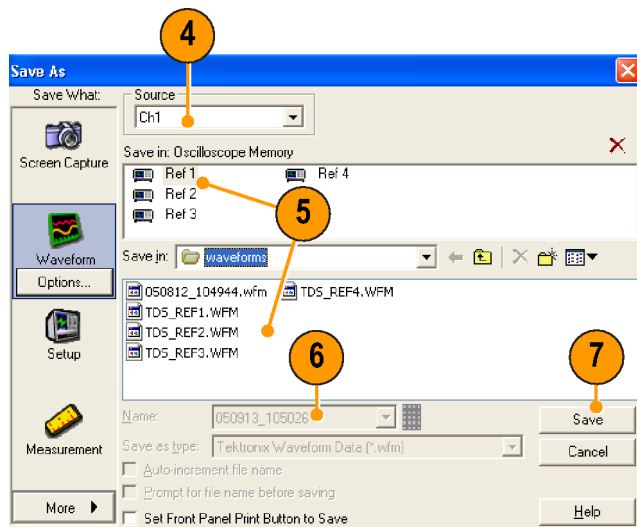

1733-158

Quick Tips

- Select **Auto-increment file name** to save numerous similar waveforms without having to retype the entire name.
- To quickly save multiple waveforms, select **Set Front Panel Print Button to Save**, and then click Save. You can now save a waveform by pushing the front-panel Print button.

Recalling Waveforms

1. Select **File > Recall...**

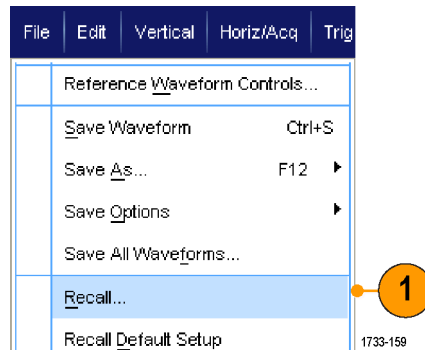

2. Click **Waveform**.
3. Select the Destination of the waveform you are recalling.
4. Select the waveform to recall.
5. Click **Recall**. Clicking Recall turns on the reference waveform and activates the Reference Waveform control window.

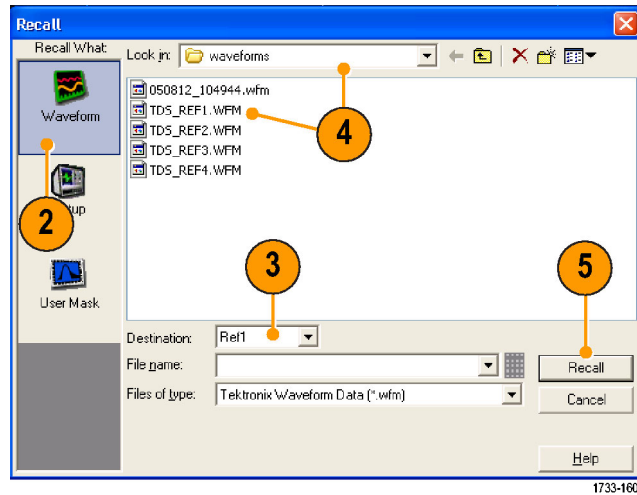

6. Use the controls to adjust the Reference waveform. You can also access the Reference Waveform control window by selecting **File > Reference Waveform Controls....**

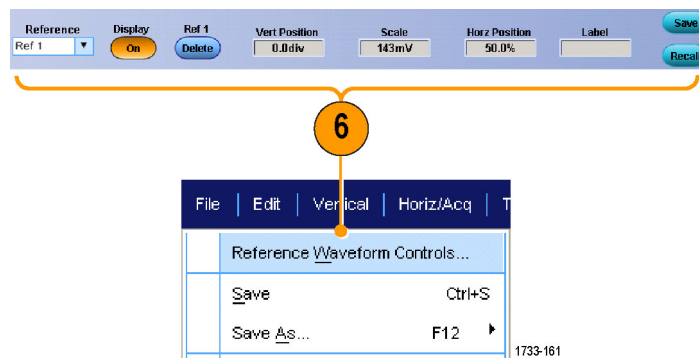

Quick Tip

- You can save a number of different file types but you can only recall setup (*.set) files and waveform (*.wfm) files.

Saving Instrument Setups

1. Select **File > Save** or **Save As > Setup...**

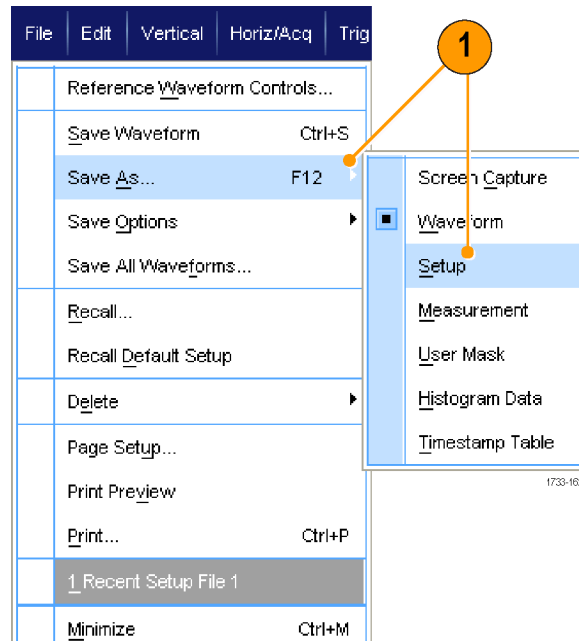

2. Click **Setup**.
3. Select the location where you want to save the setup. You can either save the setup to the instrument memory in one of the ten setup storage locations or as a .set file in a Windows directory.
4. Type a file name or use the default name. Use the pop-up keyboard to type a file name for a setup saved to the instrument memory.
5. Click **Save**.

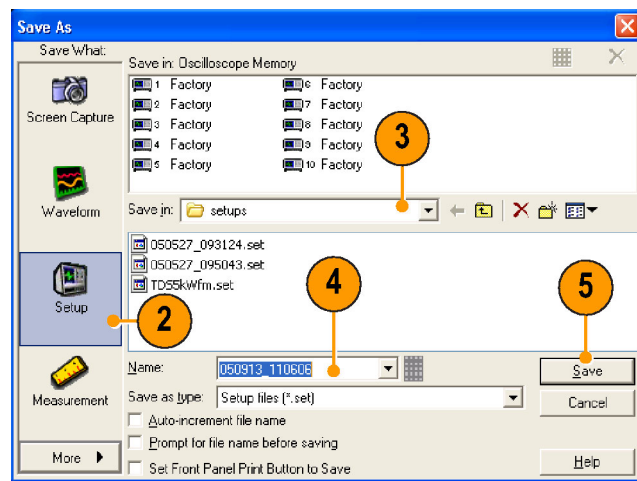

Quick Tips

- If the touch screen is enabled, use the pop-up keypad to label the setups for easy identification.
- Use Auto-increment file name to save numerous similar files without having to retype the entire file name.
- To quickly save multiple setups, select **Set Front Panel Print Button to Save**, and then click Save. You can now save a setup by pushing the front panel Print button.

Recalling Instrument Setups

1. Select **File > Recall...**

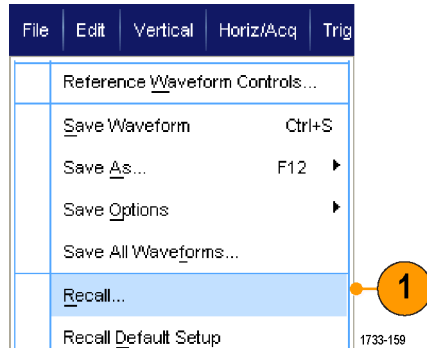

2. Click **Setup**.
3. Select the setup you want to recall. You can recall a setup file from one of the ten locations in the instrument memory or from a Windows directory.
4. Click **Recall**.

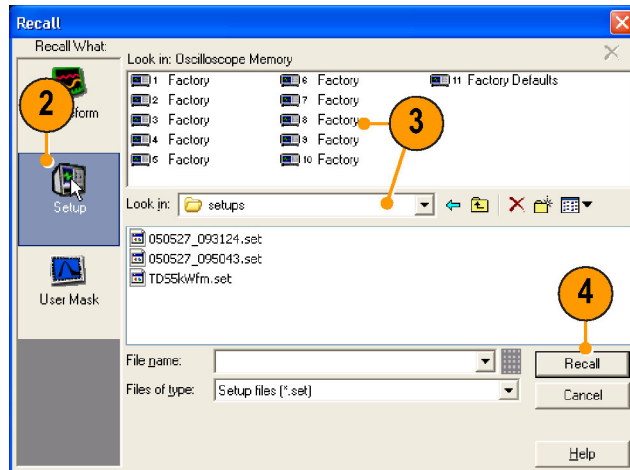

Quick Tip

- You can recall any setup stored on disk and then save it in an internal setup storage location for quicker access.

Saving Measurements

1. Select **File > Save or Save As > Measurement...**

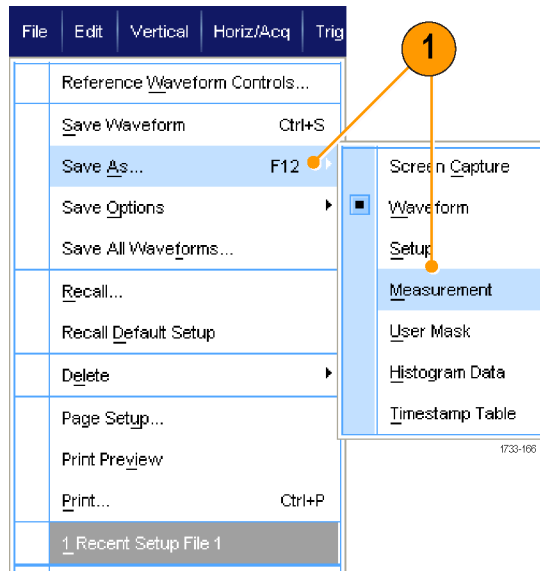

2. Click **Options...**, if you want to specify Displayed Measurements or Measurement Format; otherwise, skip to step 3.

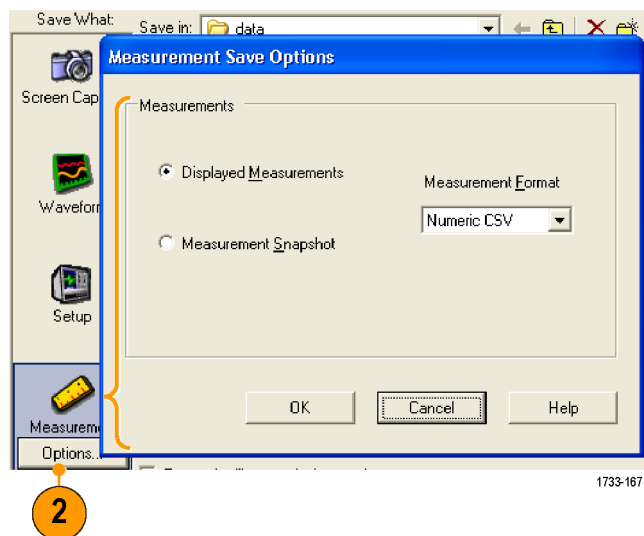

3. Select the location to save the measurement.
4. Type in a name for the measurement, and then select a file type.
5. Click **Save**.

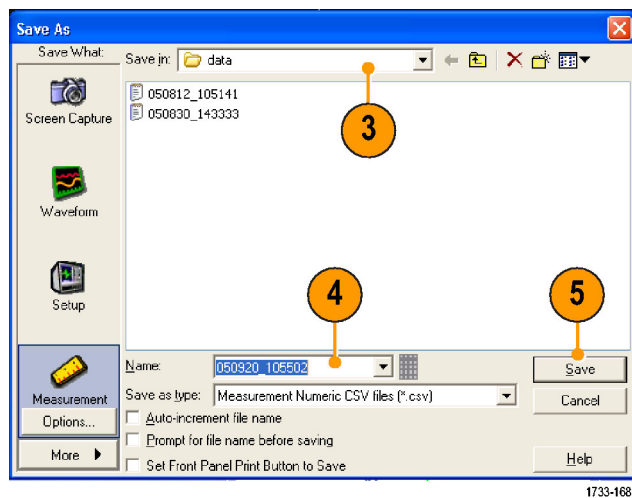

Copying Your Results to the Clipboard

Use the following procedure to set the output content and format for images, waveforms, or measurements to be copied to the Microsoft clipboard.

1. Select **Edit > Copy Setup...**

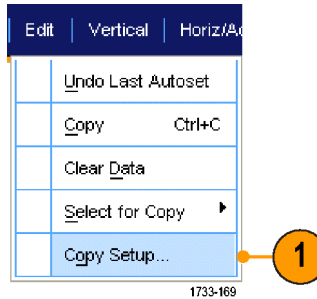

2. Click the **Images**, **Waveforms**, or **Measurements** tab, and then select the desired options.

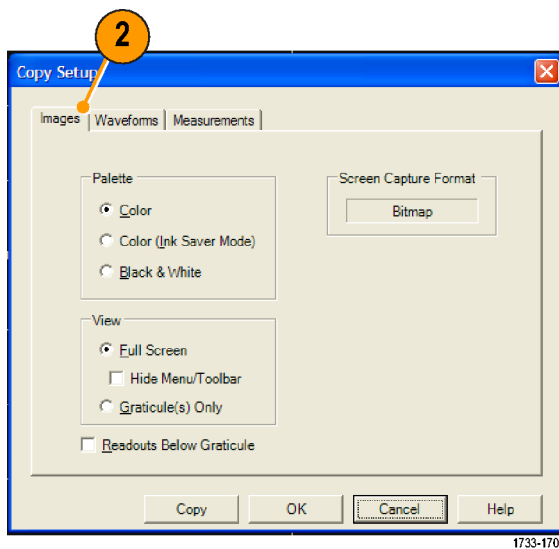

To copy images, waveforms, or measurements, use the following procedure:

1. Select the item that you want to copy.
2. Select **Edit > Copy** or press **Ctrl + C**.
3. Press **Ctrl + V** to paste the item into a Windows application.

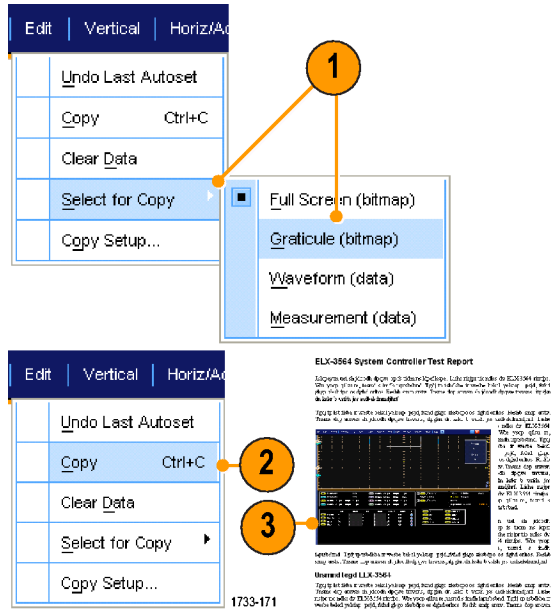

Printing a Hard Copy

- To print a hard copy, do one of the following:
 - Push **PRINT**.
 - Select **File > Print**. If necessary, you can make changes to the page orientation in the Page Setup dialog box.

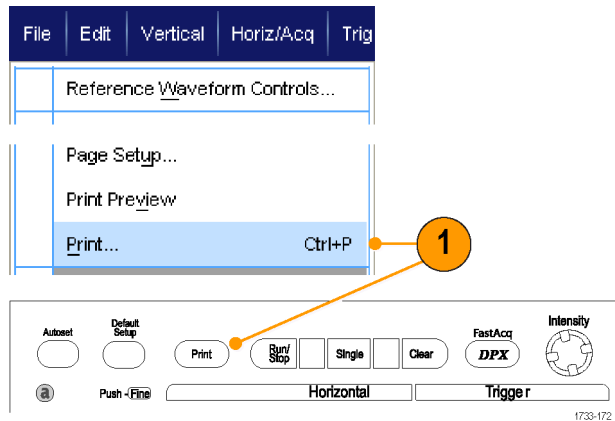

Your Print and Page Setup dialog boxes will depend on the printer you are using.

- Click **Page Setup...**

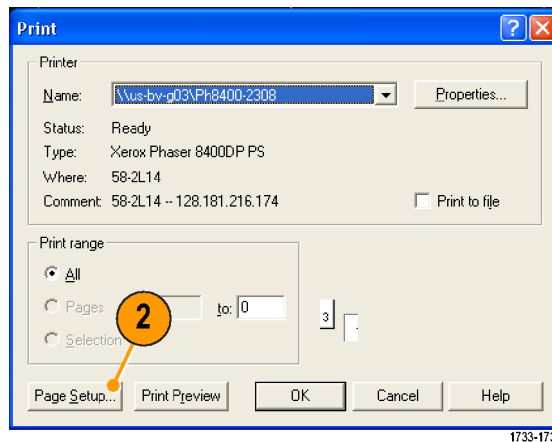

- Select the printing parameters.

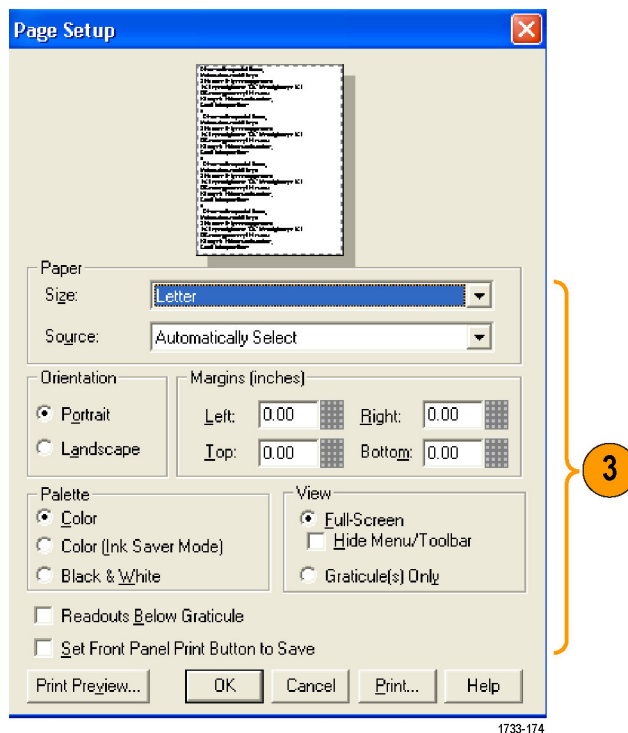

Run Application Software

The Optional Application Software CD contains free five-time trials of optional application software that you can install on your instrument. These applications provide application-specific measurement solutions. Some examples are described below. Additional packages may be available. Contact your Tektronix representative or visit our Web site at www.tektronix.com for more information.

- Use **CP2** for mask and measurements compliance testing for ITU-T G.703 and ANSI T1.102 communications standards.
- Use **DVI Compliance Test Solution Software** for DVI physical layer compliance testing.
- Use **ET3** to perform 10/100/1000 Base-T Ethernet compliance testing.
- Use **FBD RTE** module for FB-DIMM compliance for ≥ 4 GHz models.
- Use **HT3** HDMI Compliance Test Software for HDMI compliance testing.
- Use **IBA** RTE module for InfiniBand for ≥ 4 GHz models.
- Use **J2** Disk Drive Measurement Software to measure disk drive signals according to IDEMA standards.
- Use **JA3 Advanced** or **JE3 Essentials** Jitter Analysis Software to characterize timing performance. Analyze jitter on contiguous clock cycles using single-shot acquisitions.
- Use **LSA** Serial Analysis Software for CAN/LIN protocol triggering and analysis.
- Use **MTH** Communication Mask Testing Software for mask compliance testing on ≥ 4 GHz models.
- Use **MTM** Communication Mask Testing Software for mask compliance testing is available on < 4 GHz models.
- Use **MTU** Communication Mask Testing Software for mask compliance testing on ≥ 4 GHz models.
- Use **RTE** Real Time Eye Measurement Software to perform serial compliance and analysis. There are compliance modules for many serial standards.
- Use **PCE** RTE module for PCI-Express for ≥ 4 GHz models.
- Use **PTH** Serial Protocol Trigger Software to trigger and decode 8 B/10 B data on high-speed serial or data protocols. Protocol triggering up to 3.125 GS/s with Option PTH. Decode is available on all models.
- Use **PTM** Serial Protocol Trigger Software to trigger and decode 8 B/10 B data on high-speed serial or data protocols. Decode is available on all models.
- Use **PTU** Serial Protocol Trigger Software to trigger and decode 8 B/10 B data on high-speed serial or data protocols. Protocol triggering up to 3.125 GS/s with Option PTU. Decode is available on all models.
- Use **PWR** Power Measurement Software to quickly measure and analyze power dissipation in power supply switching devices and magnetic components.
- Use **SST** Serial ATA and Serial Attached SCSI compliance module with option RTE.
- Use **USB** to characterize USB2.0 signals including mask testing and parametric testing (S/W only).
- Use **VNM** CAN/LIN Protocol Analysis Software for CAN and LIN testing (CAN triggering not included).

Follow the instructions provided with the application software to install it. To run the software, select **Analyze** and then select the application.

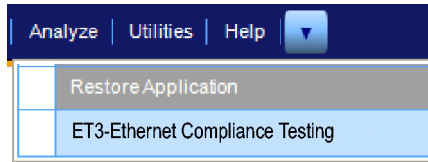

1733-175

Application Examples

This section contains ways to use your instrument in common troubleshooting tasks and extending the use of your instrument.

Capturing Intermittent Anomalies

One of the most difficult tasks that design engineers face is tracking down the cause of intermittent failures. If you know what type of anomaly you are looking for, it is easy to configure the oscilloscope advanced triggering capability to isolate it. However, when you do not know what you are looking for, it can be exceptionally tedious and time consuming, especially given the low waveform capture rate on traditional digital storage oscilloscopes.

Digital Phosphor Oscilloscopes enabled by DPX technology have an exceptionally fast acquisition mode called FastAcq, which allows you to find anomalies like these in a matter of seconds or minutes. A regular DSO would take hours or days to find the same event.

Use the following procedure to capture intermittent anomalies.

1. Connect the probe to the input signal source.

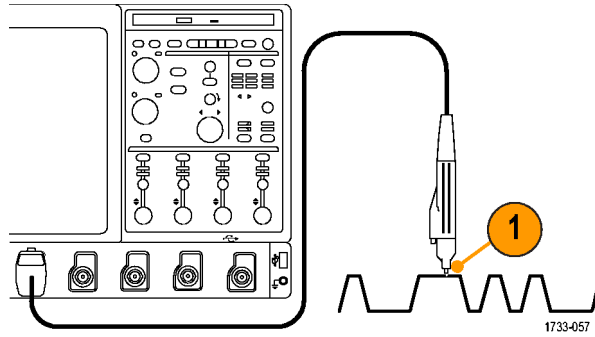

<4 GHz models

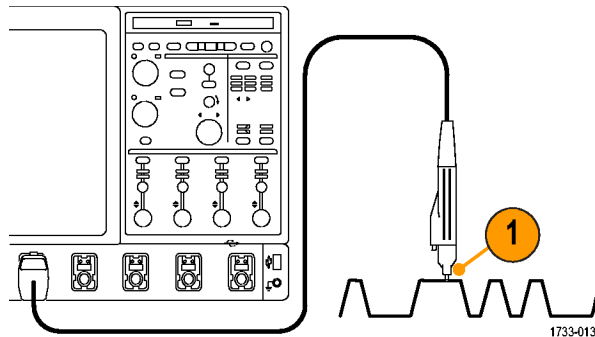

≥4 GHz models

2. Push **Autoset**.

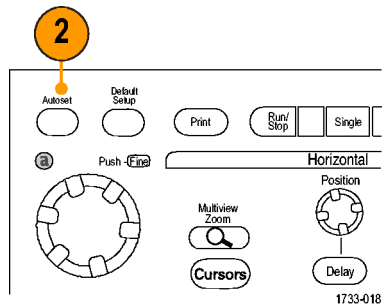

3. Select **Display > Display Persistence > Infinite Persistence**. In this example, you are looking at a clock signal. After observing the signal for 1–2 minutes, but before you look for the problem elsewhere, go to step 4.

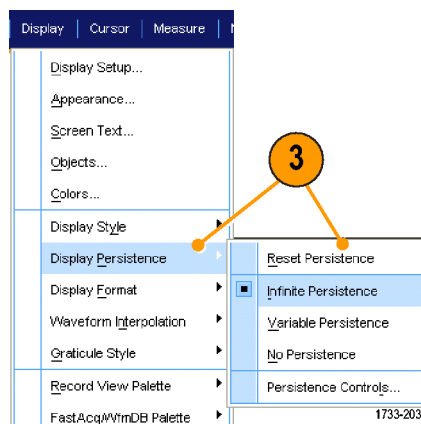

4. Press **FastAcq**.

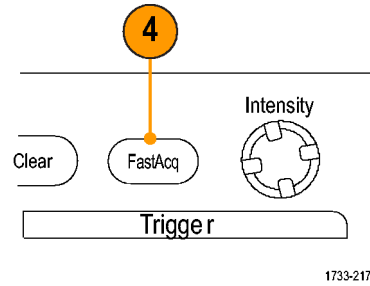

5. Find glitches, transients, or other random anomalies that are present in the signal. In this example, FastAcq revealed an ≈ 300 ns positive glitch after only a few seconds.

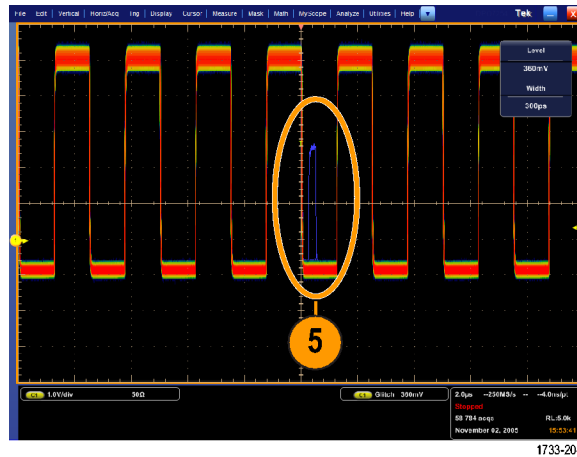

6. To trigger on the glitch that you identified in step 5, select **Glitch Setup...**
7. Select the appropriate polarity.
8. Click **Level**, and then set the level based on what you found in step 5.
9. Click **Width**, and then set the width based on what you found in step 5.

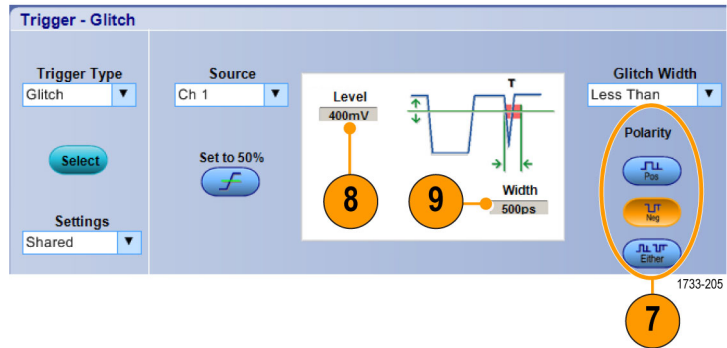
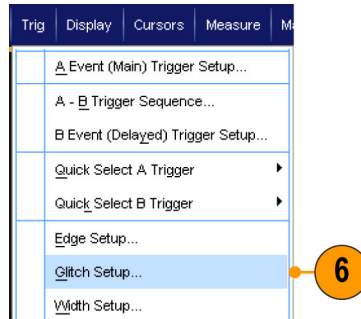

10. Click E-mail on Trigger **On**. (See page 128, *Setting Up E-mail on Event*.)

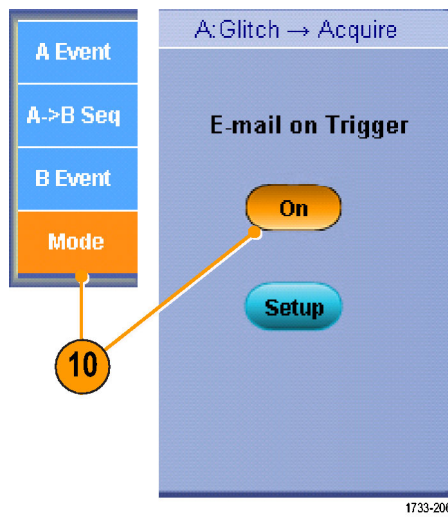

11. Push **Single** to trigger on a single glitch.

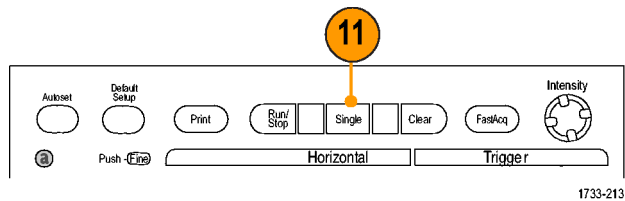

Using the Extended Desktop and OpenChoice Architecture for Efficient Documentation

Engineers often need to document their lab work for future reference. Instead of saving screen shots and waveform data to a CD or USB memory device, and then generating a report later, try using the OpenChoice architecture to document your work in real time.

To make your instrument the center of your design and documentation process, use the following procedure.

1. Load Microsoft Word or Excel on your instrument.
2. Connect a second monitor. (See page 6, *Adding a Second Monitor.*)

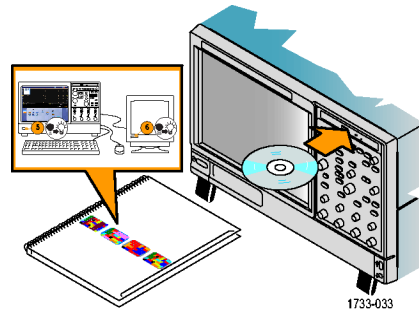

3. Open Microsoft Word, and then drag the Word window onto the extended desktop.

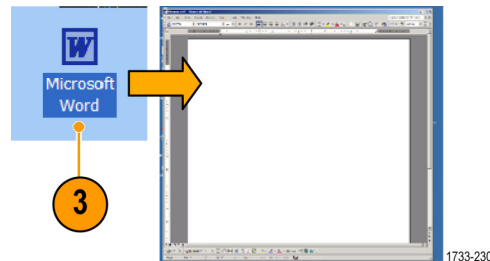

4. Click **TekScope** to restore the instrument application.



5. Select **Edit > Select for Copy > Full Screen (bitmap)**.

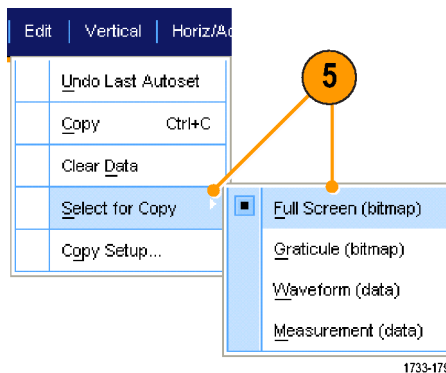

6. Press **Ctrl+C**.
7. Click in the Word document wherever you want to place the screen shot, and then press **Ctrl+V**.

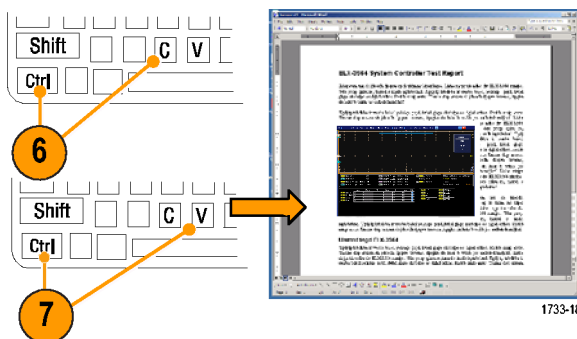

Quick Tips

- The instrument comes with a variety of OpenChoice software tools designed to ensure maximum efficiency and connectivity to the rest of your design environment.

Triggering on Buses

You can use your instrument to trigger on CAN (optional), I²C, and SPI buses. The instrument can display both physical layer (as analog waveforms) and, for CAN and LIN triggers, protocol level information (as digital and symbolic waveforms).

NOTE. Some trigger types are not available on some instruments.

To set up the bus trigger:

1. Select **Trig > A Event (Main) Trigger Setup...**

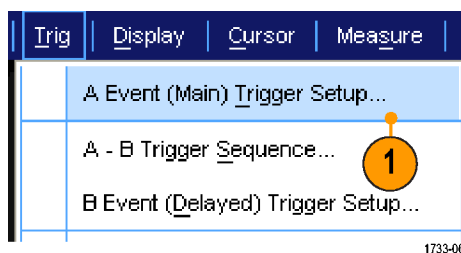

2. Set the A trigger type and source in the A Event tab.

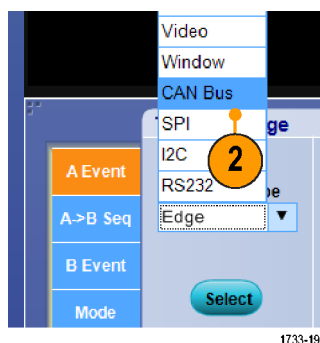

3. Select **Trigger On** to select the desired trigger on feature.

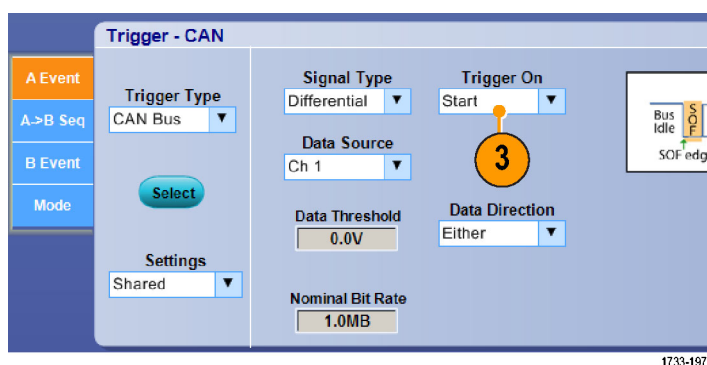

4. Depending on your **Trigger On** selection, you may need to make additional selections.

Triggering on a Video Signal

The instrument supports triggering on NTSC, SECAM, PAL, and high definition signals.

To trigger on the video fields:

NOTE. The video trigger type is not available on some instruments.

1. Select **Trig > A Event (Main) Trigger Setup...**

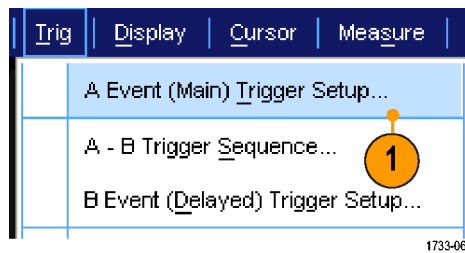

2. Set the A trigger type and source in the A Event tab.
Select **Format > 525i/NTSC**.

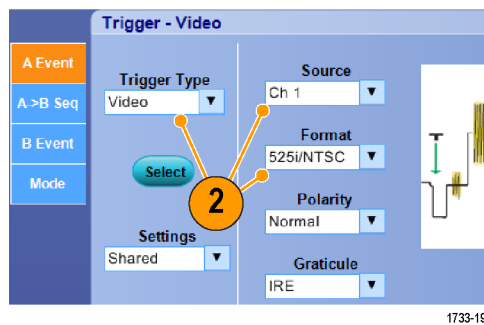

3. Select **Trigger On > Field**.
Select **Odd, Even, or All** fields.

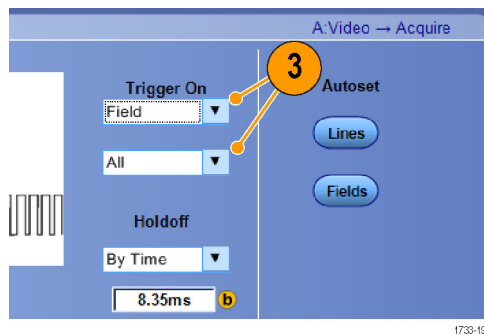

Triggering on Lines

To look at the video lines in the field:

1. Select **Trig > A Event (Main) Trigger Setup...**

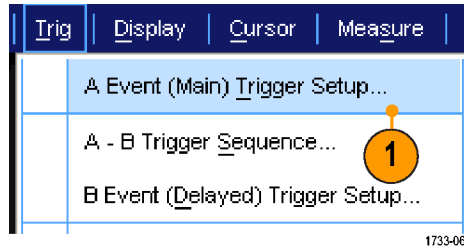

2. Set the A trigger type and source in the A Event tab.
Select **Format > 525i/NTSC**.

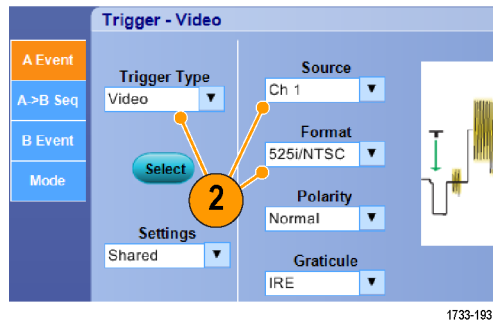

3. Select **Trigger On > All Lines**.

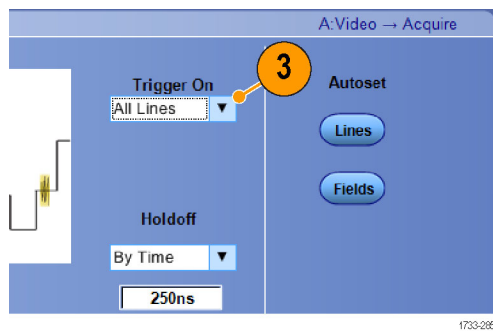

Setting Up E-mail on Event

1. Select **Utilities > E-mail on Event > Setup....**

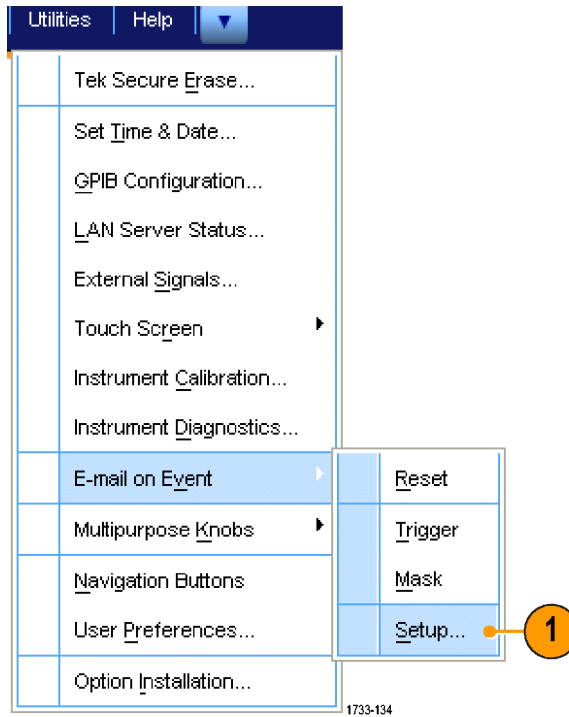

2. Enter recipients' e-mail address(es). Separate multiple entries with commas. There is a limit of 252 characters in the e-mail address box.

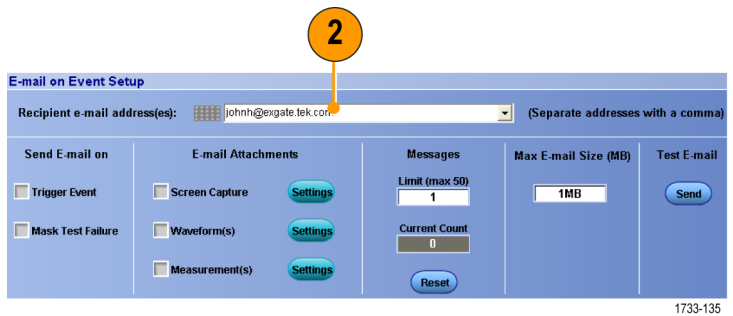

3. Click **Config**, and then enter the SMTP Server Address. Contact your network administrator for the correct address.

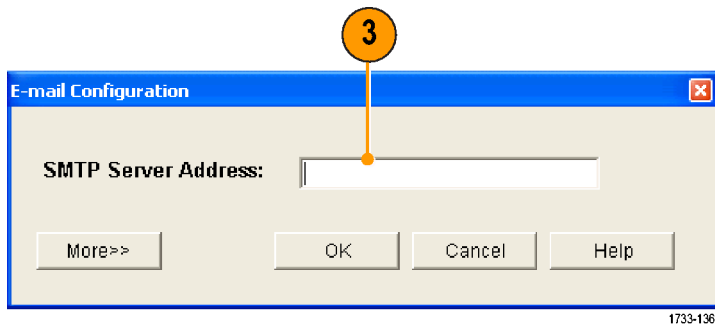

4. Select the event(s) for which you want to send an e-mail.
5. To include attachments, select the type of attachment, and then click **Settings** to specify the format.

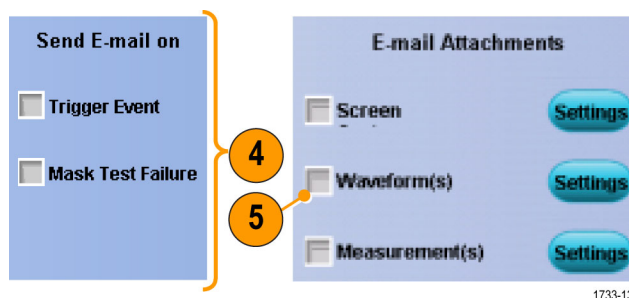

1733-137

6. Set the maximum message limit and e-mail size. (Maximum message limit is 50 and maximum e-mail size is 2000 MB). When the maximum message limit is reached, you must click **Reset** to send more e-mails on event.
7. To ensure that you have set up the e-mail addresses correctly, send a test-mail by clicking **Send**.
8. If necessary, click **Config** to access the e-mail configuration dialog box and adjust the configuration.

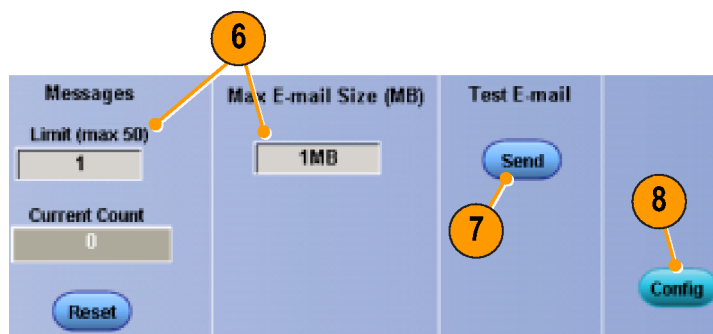

1733-138

Quick Tips

- To save attachments to your instrument hard drive, set the maximum message size to zero. The attachments will be saved to the default location C:\TekScope\Screen Captures, Waveforms, or Data depending on the type of attachment.
- Failure to enter a valid recipient's e-mail address or an SMTP Server Address displays error messages.

Correlating Data Between a Tektronix Oscilloscope and Logic Analyzer

Almost every design is a high-speed design with fast clock edges and data rates. For these designs, you need to see the analog characteristics of high-speed digital signals in relation to complex digital events in the circuit. iView is your window into the digital and analog world. The iView capability seamlessly integrates and automatically time-correlates data from Tektronix logic analyzers and oscilloscopes, so you can transfer analog waveforms from the oscilloscope to the logic analyzer display with the click of a mouse. View time-correlated analog and digital signals side-by-side and pinpoint the source of elusive glitches and other problems in moments.

The iView External Oscilloscope Cable allows you to connect your logic analyzer to a Tektronix oscilloscope, enabling communication between the two instruments. The Add External Oscilloscope wizard, which is available from the TLA application System menu, will guide you through the process of connecting the iView cable between your logic analyzer and oscilloscope.

A setup window is also available to assist you in verifying, changing, and testing the oscilloscope settings. Before acquiring and displaying a waveform, you must establish a connection between your Tektronix Logic Analyzer and oscilloscope using the Add External Oscilloscope wizard.

1. Select **Add iView External Oscilloscope...** from the logic analyzer System menu.

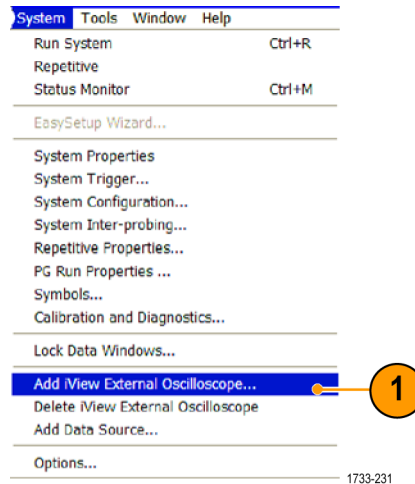

2. Select your model of oscilloscope.
3. Follow the on-screen instructions, and then click **Next**.
4. See your Tektronix Logic Analyzer documentation for more information on correlating data between the logic analyzer and the oscilloscope.

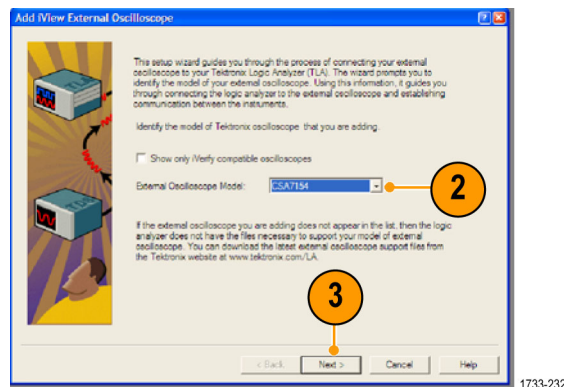

Verifying Performance Using Limit Test

Manufacturing test engineers often need to compare the performance of products coming off a manufacturing line with a known good reference product. If the signals from the device under test (DUT) are within a user-defined tolerance of the reference product, then the device passes the test. Use the following procedure to perform this type of testing with your instrument.

1. Acquire the desired signal on the reference product.

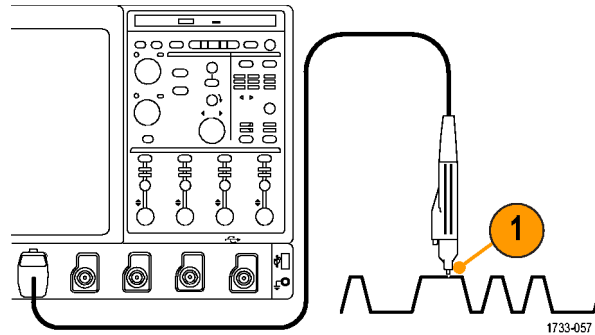

<4 GHz models

2. Select **Limit Test Setup...**

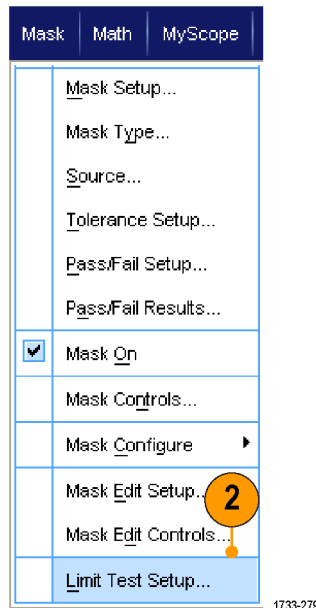

3. From the Source list, select the channel with the known good reference waveform.
4. From the Destination list, select where you want to store the template.
5. Specify how much the DUT can deviate from the template by entering Vertical and Horizontal tolerances.
6. Click **Save**. You have created a template that is a snapshot of the known good reference with the specified tolerances built into it. Notice that the template is automatically activated after you click Save.
7. Move your probe from the reference product to the DUT.

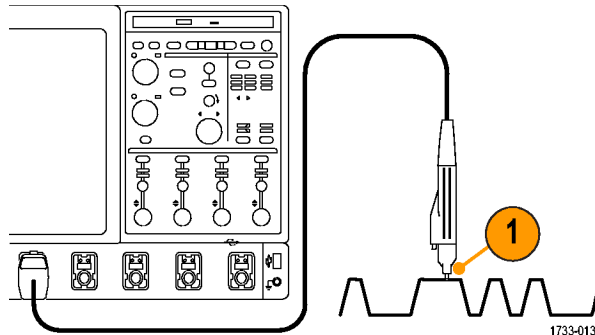
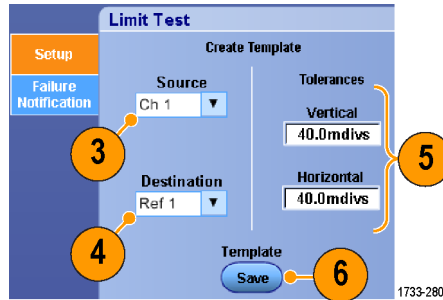

≥4 GHz models

8. Select the source channel that is connected to the DUT.
9. Select the template that you saved in step 4.

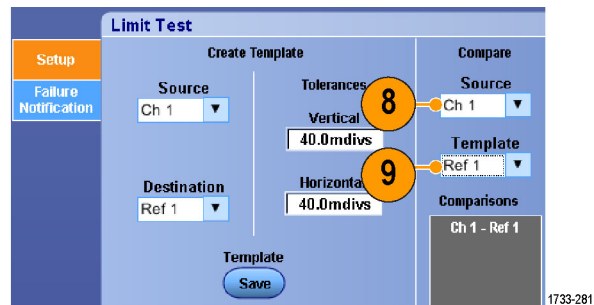

10. Click **Failure Notification** to set up the Failure Notification.
11. For this example, click Stop Acq **On**, and then click **Setup** to return to the setup control window.

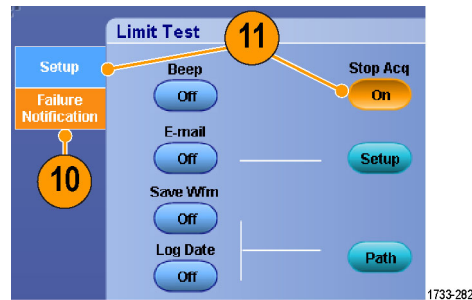

12. Click Lock Template to Waveform **On** and Highlight Hits **On**.
13. Toggle Limit Test to **On** to start the test.

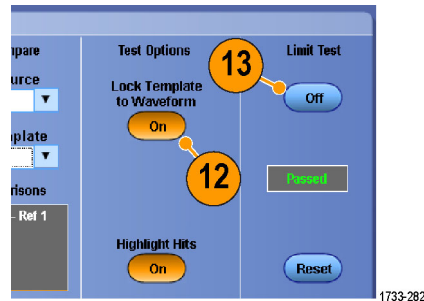

The instrument compares every waveform it acquires against the template until a waveform fails to match the template. When a failure occurs, acquisitions stop and the violations appear in a different color on the display. The following example shows Ch 1 on top so that you can see Ch 1, the template, and the hits.

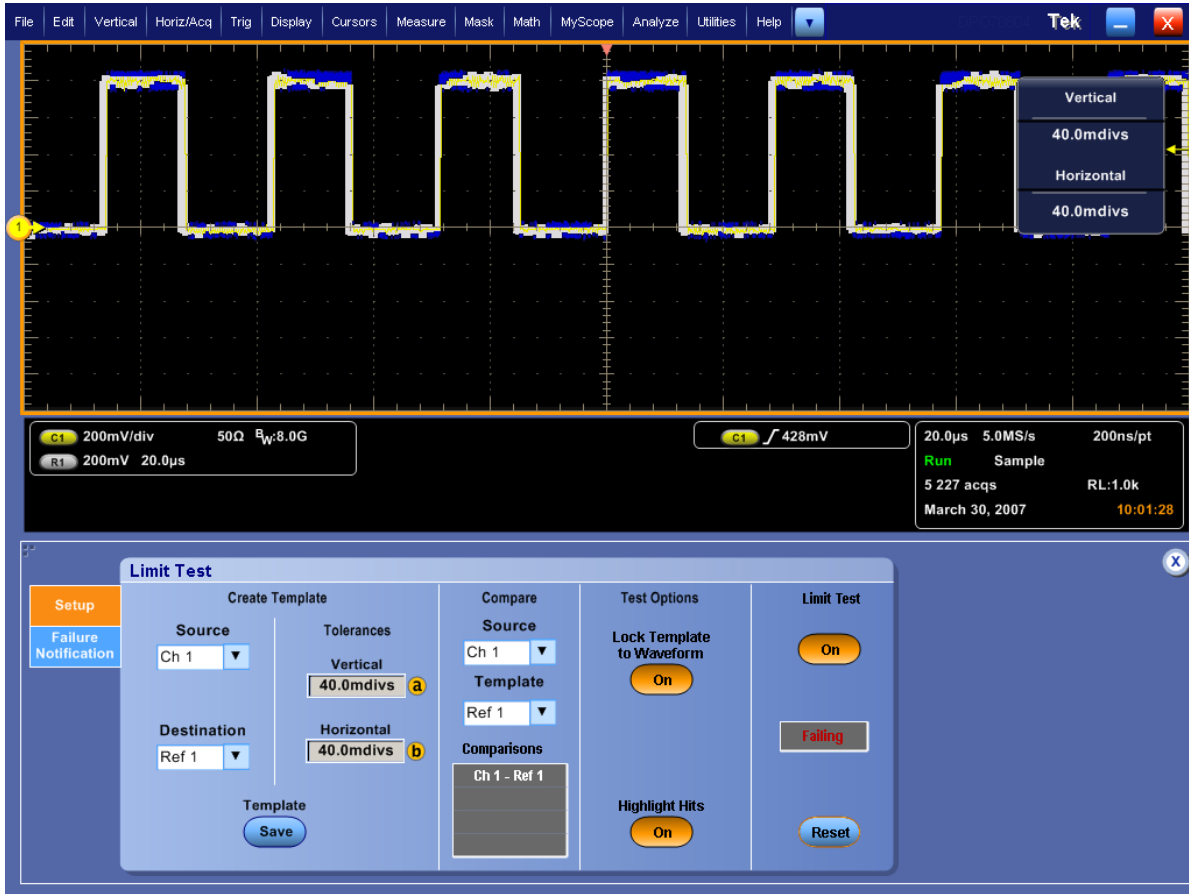

Cleaning

Use these procedures to clean your instrument. If additional cleaning is required, have your instrument serviced by qualified service personnel.

Exterior Cleaning

Clean the exterior surfaces of the chassis with a dry lint-free cloth or a soft bristle brush. If any dirt remains, use a cloth or swab dipped in a 75% isopropyl alcohol solution. Use a swab to clean narrow spaces around controls and connectors. Do not use abrasive compounds on any part of the chassis.

Clean the On/Standby switch using a dampened cleaning towel. Do not spray or wet the switch directly.



CAUTION. Improper cleaning agents, methods, or excessive force can damage the instrument. Do not use chemical cleaning agents that might damage the plastics used in this oscilloscope. Use only deionized water when cleaning the front-panel buttons. Use a 75% isopropyl alcohol solution as a cleaner and rinse with deionized water. Before using any other type of cleaner, consult your Tektronix Service Center or representative.

To prevent getting moisture inside the instrument during external cleaning, use only enough liquid to dampen the cloth or applicator.

Index

A

- Accessories, 1
- Acquisition
 - input channels and digitizers, 26
 - sampling, 26
- Acquisition modes
 - changing, 30
 - defined, 28
- Add filtering
 - user definable, 91
- Amplitude measurements, 79
- Application software, 117
- ARM status light, 47
- Automatic trigger mode, 42
- Autoscroll, 65, 66
- Autoset, 25
- Autoset Undo, 25
- Average acquisition mode, 29

B

- Bandwidth enhancement, 34
- Bandwidth limit, 36
- Bus, 125
- Buses, 125
- Button
 - Set / Clear Mark, 67

C

- Calibration, 20
- CAN, 125
- CAN trigger
 - defined, 46
- Choosing a Trigger Type, 44
- Cleaning, 134
- Color palettes, 60
- Communication
 - measurements, 81
 - trigger, defined, 45
- Control panel, 11
- Control panel map, 16
- Copying, 114
- Coupling
 - trigger, 43
- Cross Hair graticule style, 58
- Cursor measurements, 85

D

- Date and time, 59
- DDR analysis, 72
- Default setup, 24
- Delayed trigger, 43, 47
- Diagnostics, 19
- Display
 - colors, 61
 - objects, 59
 - persistence, 54
 - style, 53
- Display map, 13
- Display Remote, 6
- Documentation, ix
- Dots
 - displaying waveform record points as, 53
- DSP Bandwidth enhancement, 34
- Dual monitor, 6

E

- E-mail on event
 - setup, 128
- E-mail on trigger, 51
- Edge trigger
 - defined, 45
- Enhanced bandwidth, 34
- Envelope acquisition mode, 29
- Export *See* Saving
- Extended desktop, 6, 123
- Exterior cleaning, 134

F

- Fast Acquisition, 34, 119
- FastAcq/WfmDB palette, 60
- FastFrame, 37
 - Frame finder, 39
- Force trigger, 42
- Frame graticule style, 58
- Front panel map, 11
- Full graticule style, 58

G

- Gate width and resolution
 - bandwidth, 95
- Gating, 82

- Glitch trigger
 - defined, 45
- Glitches
 - capturing, 28, 34, 119
 - triggering on, 43
- Graticule styles, 58
- Grid graticule style, 58

H

- H Bars cursor, 86
- Hard copy, 116
- Help, 17
- Hi Res acquisition mode, 29
- Histogram measurements, 80
- Histogram setup, 88
- Horizontal delay, 52
- Horizontal marker, 63
- Horizontal position
 - and math waveforms, 92
 - defined, 24
- Horizontal scale
 - and math waveforms, 92
- How to
 - search through and add marks to waveforms, 66

I

- I2C, 125
- Incoming inspection, 19
- Infinite persistence, 54
- Instrument setup
 - recalling, 112
 - saving, 111
- Intensified samples
 - displaying waveforms as, 53
- Inter-IC Control trigger
 - defined, 46
- Interface map, 13
- Interpolation, 28, 56
- iView, 130

L

- Label, 57
- Limit test
 - example, 131
- Limit testing, 98

Linear interpolation, 56
Lock zoomed waveforms, 65, 66
Logic analyzer
 correlating data, 130

M

Main trigger, 43, 47
Mark, 66, 67, 68
Mask
 autofit, 96
 autoset, 96, 98
 margin tolerance, 97
 pass/fail testing, 97
Mask testing, 95
Math
 arbitrary filters, 92
 colors, 61
 editor, 90
 waveforms, 90
Measurements, 77
 accuracy, 26
 annotation, 84
 cursor, 85
 customizing, 81
 defined, 79
 reference levels, 85
 saving, 113
 snapshot, 83, 84
 statistics, 82
Menus, 18
Monochrome gray color palette, 60
Monochrome green color palette, 60
More measurements, 80
Multiple zoom areas, 63
MultiView zoom, 61
MyScope
 editing, 105
 new control window, 101
 using, 105

N

Network connection, 6
Normal color palette, 60
Normal trigger mode, 42

O

Objects
 display, 59
Online help, 17
OpenChoice
 example, 123

Operating specifications, 2
Overlay frames, 39

P

Pattern lock trigger, 45
Pattern trigger
 defined, 45
Peak Detect acquisition mode, 28
Persistence
 display, 54
Pinpoint Trigger Selections, 45
Pinpoint Triggers, 42
Posttrigger, 42, 43
Power off, 5
Power on, 4
Power supply, 4
Predefined math expressions, 90
Predefined spectral math
 expressions, 92
Pretrigger, 42, 43
Print, 116
Probe
 calibration, 26
 compensation, 26
 deskew, 26

R

Random noise, 29
Readout
 trigger, 47
READY status light, 47
Rear panel map, 12
Recall
 setup, 112
 waveforms, 110
Record view palette, 60
Reference colors, 61
Reference levels, 85
Related documentation, ix
Remote Display, 6
Right-click menu, 18
Roll mode, 37
Roll mode interactions, 37
RS-232 trigger
 defined, 46
Runt trigger
 defined, 45

S

Safety Summary, v
Sample acquisition mode, 28

Sampling
 equivalent-time, 27
 interpolated real-time, 27
 real-time, 26
Sampling process
 defined, 26
Saving
 e-mail attachments, 129
 measurements, 113
 screen captures, 107
 setup, 111
 waveforms, 108
Screen cursor, 86
Screen shots
 saving, 107
Screen text, 57
Scroll zoomed waveforms, 65, 66
Search, 66, 67, 68
Segmented memory, 37
Sequential triggering, 47
Serial, 125
Serial mask testing, 95
Serial trigger
 defined, 45
Set / Clear Mark button, 67
Setup/Hold trigger
 defined, 45
Shortcut menu, 18
Side panel map, 12
Signal input, 23
Sin(x)/x interpolation, 56
Single sequence, 31
Snapshot, 83, 84
Software
 optional, 117
Specifications
 operating, 2
 power supply, 4
Spectral analysis, 92
Spectral grading color palette, 60
Spectral math expression
 advanced, 93
SPI, 125
SPI trigger
 defined, 45
Start an acquisition, 31
State trigger
 defined, 45
Statistics, 82
Stop an acquisition, 31

T

- Temperature grading color palette, 60
- Time measurements, 79
- Time Stamps, 39
 - defined, 37
- Timeout trigger
 - defined, 45
- Transition trigger
 - defined, 45
- TRIG'D status light, 47
- Trigger
 - concepts, 42
 - coupling, 43
 - forcing, 42
 - holdoff, 42
 - level, 43
 - modes, 42
 - posttrigger, 42, 43
 - pretrigger, 42, 43
 - readout, 47
 - Serial, 125
 - slope, 43
 - status, 47
- Trigger event
 - defined, 42
- Trigger level markers, 59
- Trigger Position, 50
- Trigger types
 - defined, 45

U

- Undo Last Autoset, 25
- User defined color palette, 60
- User marks, 66
- User preferences, 25

V

- V Bars cursor, 86
- Variable persistence, 54
- Vectors
 - displaying waveforms as, 53
- Vertical position, 24
- Vertical position and autoset, 25
- Video
 - Lines, 126
- Video trigger
 - defined, 45
- Video triggering, 126

W

- Waveform
 - cursors, 86
 - display style, 53
 - recalling, 110
 - saving, 108
 - search and mark, 66
 - user marks, 66

- Waveform database acquisition
 - mode, 29
- Waveform record
 - defined, 28
- Width trigger
 - defined, 45
- Window trigger
 - defined, 45

X

- X-Y display format, 55
- X-Y-Z display format, 55

Y

- Y-T display format, 55

Z

- Zoom, 61
- Zoom graticule size, 62

